

# CAR DIAGNOSTICS

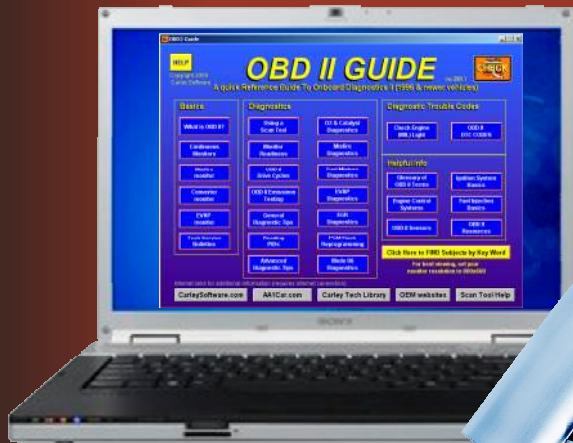

*Car diagnostics  
step by step*



OBD diagnostics without the use of devices  
OBD I diagnostics  
OBD II diagnostics  
The most common causes of DTC faults  
ECU Flashing and Mapping  
EVAP system  
Immobilizer  
Radio decoding  
Control Module or ECM/PCM repair



**Radovan MARIN**







**Author**

**Radovan Marin**  
General Automobile Engineer  
British Institute of Engineering Technology  
Aldermaston College  
Reading, England

**Reviewer**

**Dr. sc. Darko Biljaković**

**Editor**

**and**  
**Graphic design**  
**Radovan Marin**

**Publisher**



**ZAGREB**  
Kamaufova 2  
[www.auto-mart.hr](http://www.auto-mart.hr)

**Zagreb, January 2013.**

**National University Library in Zagreb**  
**ISBN 978-953-95888-4-5**



## R E V I E W

When a failure occurs on our car, the first step that we expect from our servicer is accurate or nearly accurate diagnosis, because misdiagnosis has multiple unwanted consequences. To be able to determine what is not working properly, we have to move in the direction our author went. First we have to learn how the modern car works, and then we will be able to figure out how to detect failure. The diagnosis is generally result of experience and a multidisciplinary synthesis of knowledge. Therefore, a new book of Mr. Radovan Marin “*Car diagnostics*” connects his previous books, “*Automobile electronics & 4-stroke engines*” and “*Automobile technology*”.

And this time I am pleasantly surprised by the new interesting data and high quality of expression, as well as with a great number of images. With this book, author has increased the value of his previous books, which now form a complete trilogy.

With a risk of repeating myself, I must point out that author has chose the type of presentation which is a happy compromise of a lot of conflicting requirements such as high skill, legibility, convenience, didacticism and methodology.

After these three books, it becomes apparent that Mr. Marin is a person with the rare gift of true professionalism, eager for new knowledge, and more importantly, with the gift of a good writer and a desire to convey his knowledge to a wider population. As new technologies are rapidly developing, I am confident that in due time we shall witness new books about our pets on four wheels. I strongly recommend purchasing of the entire trilogy, because that would make every part of it to be worth more than it would have been separately.

Dr. sc. Darko Biljaković





## FOREWORD

After a great acceptance of previous two books "*Automobile electronics & 4-stroke engines*" and "*Automobile technology*", automobile technicians showed further interest for detailed explanation of vehicles diagnostics and usage of diagnostics equipment. With this third book, the theory of automobile mechanics, electrics and electronics on modern cars is generally covered. By mastering content of these three books, technicians will undoubtedly acquire basic knowledge to deal with most problems on automobiles. Acquired theoretical knowledge accompanied with everyday's practical work, which always brings new experiences, will definitely create a very professional automobile craftsman. It is quite understandable, that acquired knowledge has to be complemented by following new technologies and modifications of existed.

We should be aware of the fact, that diagnostics programs are sometimes very complex, and have to be considered very seriously. If we would go in details explaining all functions of particular programs and problems related to diagnostic trouble codes, a book of several thousands pages has to be written. This book should provide even more than just fundamentals of car diagnostics, but certainly not complete knowledge which is gained by experience and further learning. Therefore, before using a particular diagnostic program, it is recommendable to study all available literature about it.

With such introduction about the principles of diagnosing faults, and assuming that we have mastered the theory from previous two books, we will surely be able to deal with diagnosed problems and eliminate them.

During the writing of these three books, in addition to several decades of experience, all worldwide available literature related to this subject matter was used. Beside the literature composed by several authors, knowledge and experiences of individual authors are used too. As it is evident from the books contents, examples are shown from a range of programs and automobile data. Just because of so great number of literature and programs used in these books, the sources, titles and authors are not mentioned by name.

Author

## Content:

<b>CAR DIAGNOSTICS</b> .....	10
Electronic Engine Management .....	10
Diagnosing an engine failure without the use of devices .....	12
<i>SRS</i> diagnostics without the scanning device .....	19
<i>ABS</i> diagnostics without the scanning device .....	22
Resetting service intervals without the use of devices .....	24
<b>OBD I</b> .....	25
Diagnosing failure with diagnostic device .....	25
<i>K</i> and <i>L</i> diagnostics lines .....	27
<i>KL</i> diagnostics .....	29
Installing <i>KL</i> interface and software .....	33
<b>OBD II</b> .....	48
Using the <i>OBD II</i> software and interface .....	52
Handheld scanners .....	65
<i>OBD II</i> and new vehicles .....	67
Pending codes <b>P0xxxx</b> * .....	69
The most common causes of trouble codes .....	70
<i>O2</i> sensor <i>DTC</i> problems .....	70
<i>MAP</i> sensor <i>DTC</i> problems .....	72
<i>TPS</i> sensor <i>DTC</i> problems .....	73

<b><i>CTS</i> sensor <i>DTC</i> problems .....</b>	<b>75</b>
<b><i>Misfire</i> <i>DTC</i> problems .....</b>	<b>78</b>
<b><i>EGR</i> valve <i>DTC</i> problems .....</b>	<b>80</b>
<b><i>CKP</i> sensor <i>DTC</i> problems .....</b>	<b>82</b>
<b>Turbocharger <i>DTC</i> problems .....</b>	<b>84</b>
<b>Wideband O2 sensor with 5 wires .....</b>	<b>85</b>
<b>Evaporative Emission Control System (EVAP) .....</b>	<b>87</b>
<b>ECU Flashing i Mapping .....</b>	<b>89</b>
<b>Immobilizer .....</b>	<b>95</b>
<b>Additional protection from car theft .....</b>	<b>101</b>
<b>Radio decoding .....</b>	<b>108</b>
<b>Car parking sensor system .....</b>	<b>112</b>
<b>Control Module or ECM/PCM repair .....</b>	<b>116</b>
<b>Transistor testing .....</b>	<b>120</b>
<b>Resistor testing .....</b>	<b>124</b>
<b>Capacitor testing .....</b>	<b>126</b>
<b>Cruise control .....</b>	<b>129</b>
<b>Start/Stop system .....</b>	<b>135</b>
<b>Regenerative braking system .....</b>	<b>138</b>
<b><i>HHO</i> .....</b>	<b>139</b>

# CAR DIAGNOSTICS

## *Electronic Engine Management*

In the previous two books, *Automobile electronics & 4-stroke engines* and *Automobile technology*, it is pretty thoroughly explained the principle of new types of petrol and diesel engines, as well as electronic engine management and other car components. Bearing in mind that users of these two previous books have studied them, and they are now clear with a function of the electronic management and its associated components, i.e. sensors and actuators, in this book we will proceed with process of diagnosing faults in the electronic system using diagnostic devices, and without them on the types of vehicles where it is predicted by manufacturers.

The concept of basic diagnostics was explained in the first book: *OBD* diagnostics, protocols and use of diagnostic tools. With this basic knowledge many people was enabled to use diagnostics tools and understand the purpose and possibilities of their use in combination with the acquired knowledge about the function and manner of testing sensors and actuators in the vehicles. All those who have used their newly acquired knowledge in practical application are aware of its complexity and almost daily updating demand. So, let's go ahead, or continue in following order.

In the beginning, let's recapitulate our knowledge related to the electronic engine management and transmission under the common name *Powertrain*.

Engine computer, or we can say command center, in which all the information are flowing in from a wide range of sensors and commands are sent out to a range of actuators is known as *ECU*, or on the newer cars *PCM Powertrain Control Module*.

Lambda probe or *O<sub>2</sub>* sensor provides information about saturation of carbon monoxide in air-fuel mixture after combustion. On the base on received information the computer adjusts the mixture, constantly keeping proper air-fuel ratio and thereby minimizing fuel consumption and emission of harmful gases. In newer cars an additional lambda probe is fitted and located behind the catalyser or downstream. This probe measures the final value of emissions and may also indicate a malfunction of the catalyst. Lambda probe is somehow popular among mechanics to cause a series of failures, and often interpreted as the cause of problems related to improper engine operation. Lambda probe malfunction will cause increased fuel consumption, performance loss and increased emissions, but the engine will still operate satisfactorily. Namely, in the case of *O<sub>2</sub>* sensor failure, computer will con-

trol injectors by spare installed program which will regulate the amount of fuel injected relying on following parameters: engine speed, intake air quantity, etc. In other words, the dosage of fuel based on these parameters will be quite correct, but not ideal as in the case of the properly functioning probe.

Coolant Temperature Sensor *CTS* is very important for the engine cold starting and driving before the engine reaches operating temperature. Having received information about the engine coolant low temperature, computer will inject greater amount of fuel and proportionally reduce it as the temperature increases. After reaching operating temperature, the computer will rely on the parameters received from lambda probe.

Parameters of the *TPS*, throttle position sensor, on the engine inlet manifold, computer will use, along with other sensors parameters, for proper ignition timing and fuel dispensing. One of the most important data of this sensor is sudden acceleration, when computer have to inject a greater amount of fuel to avoid the engine sudden stoppage (dead spot) caused by entry of large amounts of air into the engine.

*MAF*, mass air flow sensor, provides the information about the amount of intake air at certain engine speed which computer will use in the calculation of fuel dispensing.

Depending of the type of engine, *MAP* manifold air pressure sensor and *IAT*, intake air temperature sensor, can be installed in conjunction with the *MAF* sensor or without it. The parameters of these two sensors will further assist in the proper dosage of fuel, depending of intake air temperature and engine load.

Engine crankshaft position sensor *CKP* at any point shows the position of the crankshaft and pistons. Data from this sensor will allow the engine computer determining the exact moment of fuel injection and spark on the spark plugs. This is the only sensor due to which failure engine will not run.

Besides the *CKP* sensor, on higher performance engines one or two camshafts *CMP* sensors are fitted too. These sensors send information about the exact position of camshafts and thus the exact time of engine valves opening and closing which facilitates accurate calculation of ignition timing and fuel injection.

Knock sensor records the vibrations, or knocking, caused by the detonations inside the engine cylinders. The received signal computer will use to adjust the ignition timing and prevent premature ignition of the mixture due to inadequate fuel octane value or higher engine loads.

These sensors are an integral part of the today's car engine management. Additionally, depending on the type of vehicle, we

will find a number of other sensors on the engine which further improve engine function and performances. As sensors are essential for proper engine functioning, so they exist in other vehicle devices too: transmission, *ABS*, air conditioning, *SRS* ... controlled by separate modules or computers.

On today's cars, it would be impossible to achieve high performance and simultaneously satisfy global regulations related to pollution emissions, without the use of electronics. Very rigorous emission regulations forced the car manufacturers to introduce a very complex electronic engine management which increased production costs. On the other hand, new technologies have multiplied and improved engine performance, thus saving on the production of robust high capacity engines that have been, until now, incorporated into high-performance cars.

Electronic vehicle's management, at first glance, seems quite daunting. However, if the material from the previous two books has been mastered, with the help of instructions in the following chapters and the various, now available, diagnostic tools at affordable prices, and even without them in some cases, we will be able to diagnose the most failures in the electronic car systems. Why the most? It is not uncommon for the DTC to occur as a consequence of other DTC, in which case it takes a lot of knowledge and experience that is gained over time to solve the prob-

lem. In any case, using the current knowledge and some effort, we will be able to diagnose even such failure by eliminating consequential DTC on the basis of checking the validity of some electronic elements, and logical conclusions derived by linking their functions and interactions.

### *Diagnosing an engine failure without the use of devices*

As already mentioned in previous publications, OBD or On Board Diagnostic means that the engine computer diagnosis DTC of electronic systems and stores them in the form of codes in its memory. Some carmakers have predicted the possibility of accessing the codes without diagnostic devices. It is mostly the case on Japanese cars, not late models, and can be also found in most European car models.

As on the newer cars generation almost nothing is simple, even such process of diagnosis will not be possible without the assistance of provided auto-data. As each type of car has a specific way to access data from the engine computer, we need to find the vehicle manufacturer's instructions. Such information can be found in various commercial vehicle data programs, which are conducted under various names. One of the most popular is Autodata. In the lack of such commercial data, a little wiser and more persistent may seek instructions on the Internet.

For the first example to diagnose failure on the engine elec-



tronic management we will take the car model Honda Civic 1.4 made 2000. Here we shall use the instructions from the one of many databases available *Autodata*. In browser we choose: the year of manufacture, brand and model of vehicle. In the right column we see

the capacity of engine installed in this model of this car, and at the bottom of the page we can select the type of engine selected by serial number and power. In the program header, we will select the option to diagnose trouble code or DTC. By clicking on the selected

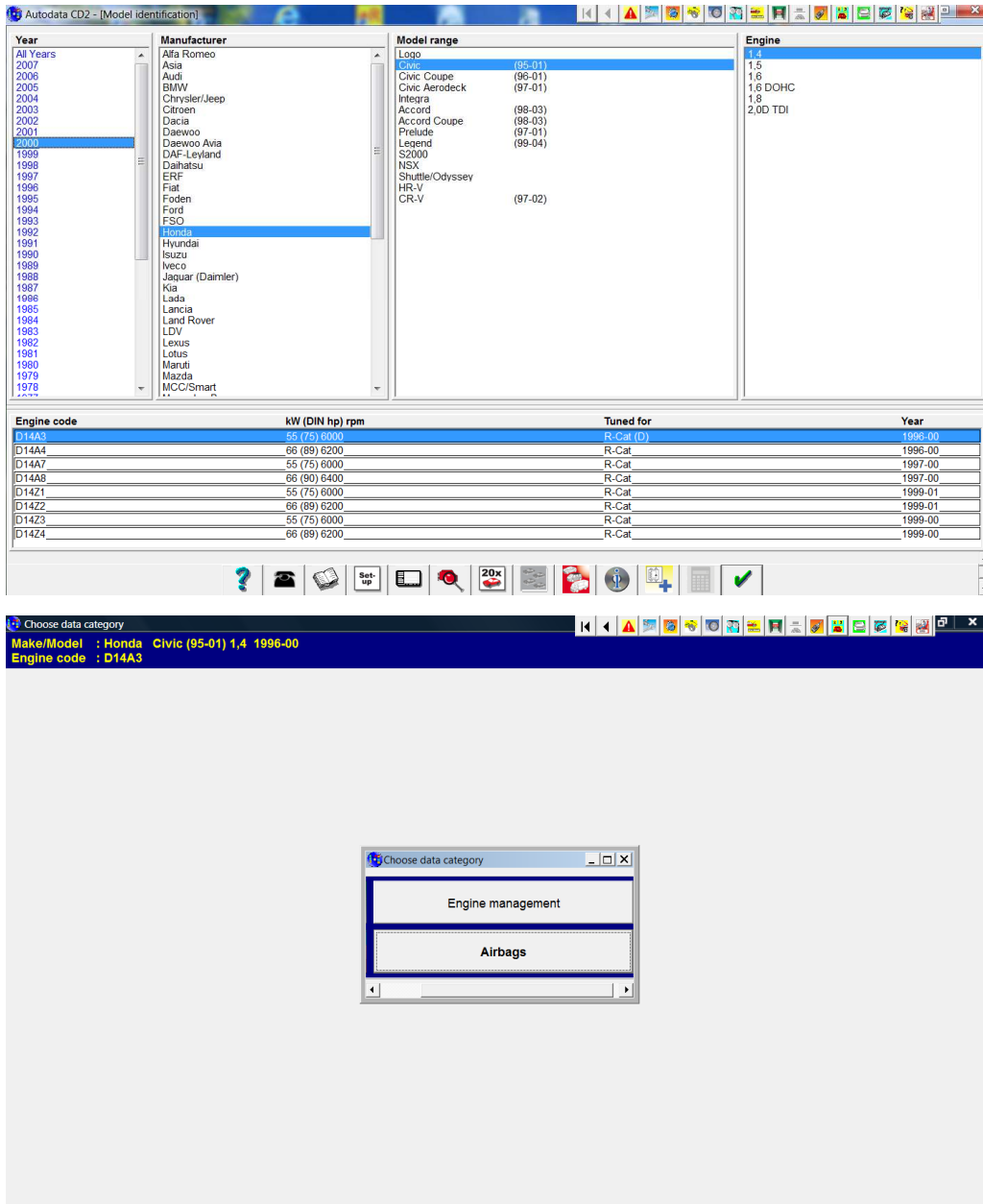

option, two additional options are offered: engine management and air bags. To begin, we choose the first option. On the newly opened window we can immediately notice the ability to diagnose without the assistance of the diagnostic device. In fact, otherwise in the right column only one sentence would be written which indicates that access is only possible with diagnostic device. In such happy circumstances where we can access the data from the computers without diagnostic equipment, fault diagnosis can be approached in the following order: in the left column, we are offered 5 different connectors for plugging diagnostic devices (in most cases it is just one) and sketch of its position in cab car. Concluding that in our car we have connector with only two terminals, we shall select Type 1 solution. In the case of connector with multiple terminals, we

shall click on different type of connector opening its sketch. Choosing connector identical to the vehicle's we are prompted to the option of general information. In the right column of the new page we get information to read error codes by counting the flashes of the MIL light, actually the same light which warns us about the faults in electronic management.

Further information from this site in our case is not so important, and therefore we shall go directly to the option on the left, or: Accessing data. On this page, in the column on the left we see the connection or connector where terminals 1 and 2 are bridged with a piece of wire. Let's go to the right column of the page and follow the exact procedure describing accessing data. Instructions go in this order: bridge terminals 1 and 2 on two terminals connector, do not

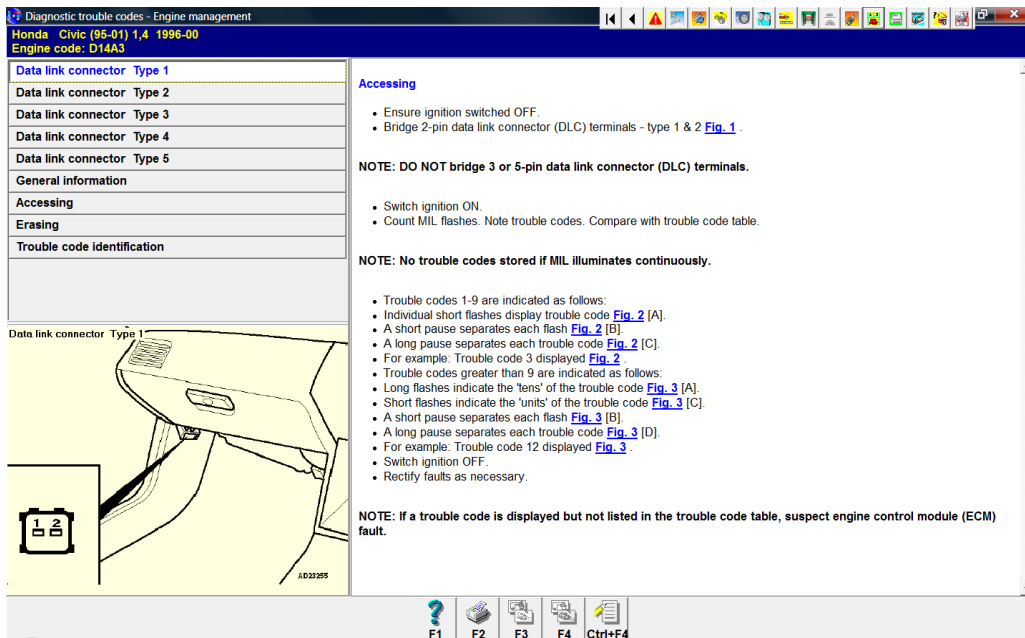

bridge the terminals on the three and five terminals connectors, switch the ignition ON, count the flashings of MIL light on the instrument panel, write down the codes defined by flashings and compare them with the code's ta-

ble. If the MIL light illuminates constantly, there are no faults stored in the engine computer. Further on, follow instructions how to read trouble codes by counting flashings and following pauses between them. Error codes

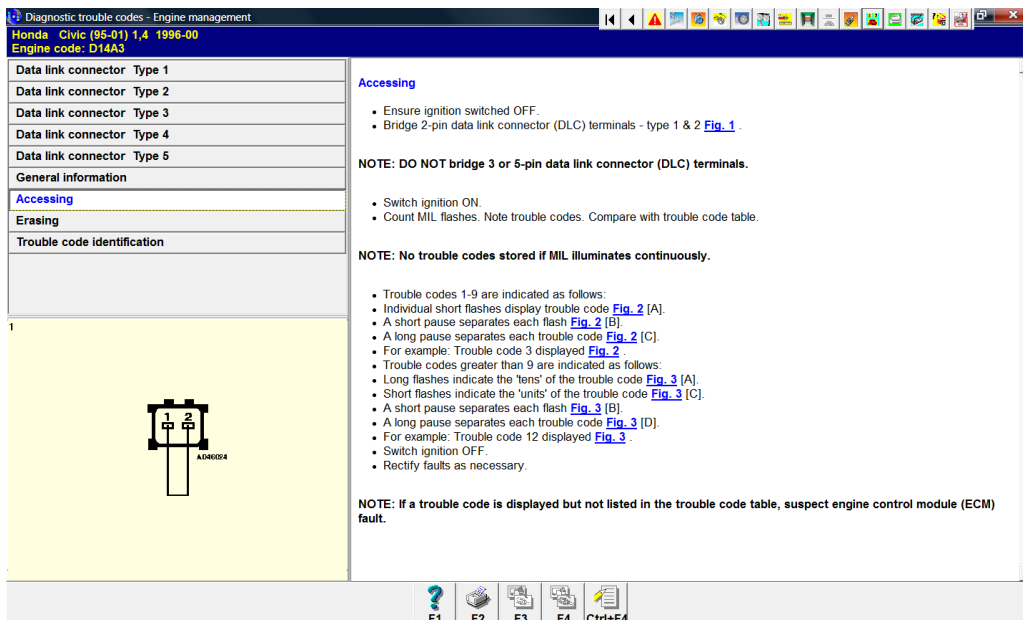
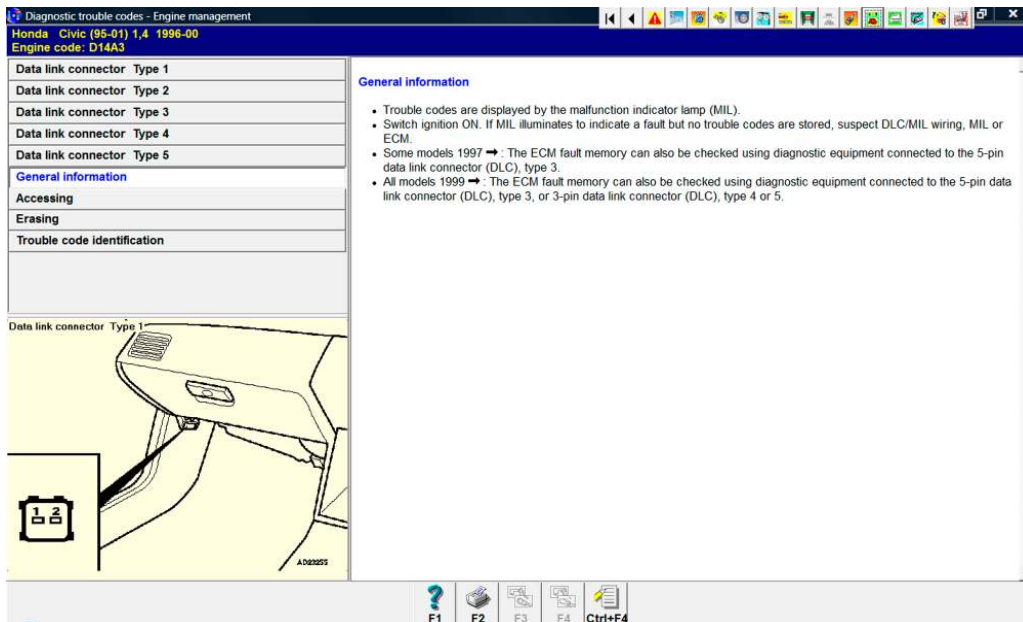

from 1-9 are shown in the following order: the number of short flashings followed by short breaks indicates the error code. In this case, the code number 3 is visible on the sketch in the lower left corner of the column. A longer pause between flashings separates the codes, or we read the new code. Error codes with values greater

than 9 are read as follows: a longer duration of flashings indicates the value 10, each following brief flash followed by short break has a value of 1, long pause marks the end of the code and next code comes up if exists. On the previous

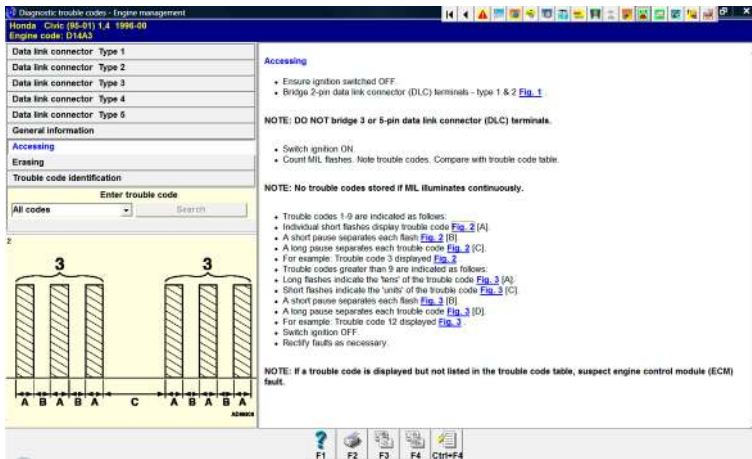

turn the ignition OFF, remove the wire that we bridge the terminals, remove the fuse of 7.5 A sketched on the left, and put it back after 10 to 15 seconds. There are two sketches of the fuse, depending of the engine type listed on the right side. The DTC can be also erased by removing one of the battery terminals for 10 to 15 seconds.

Finally, like all other jobs when they are done, they look simple and easy. However, finishing diagnostics

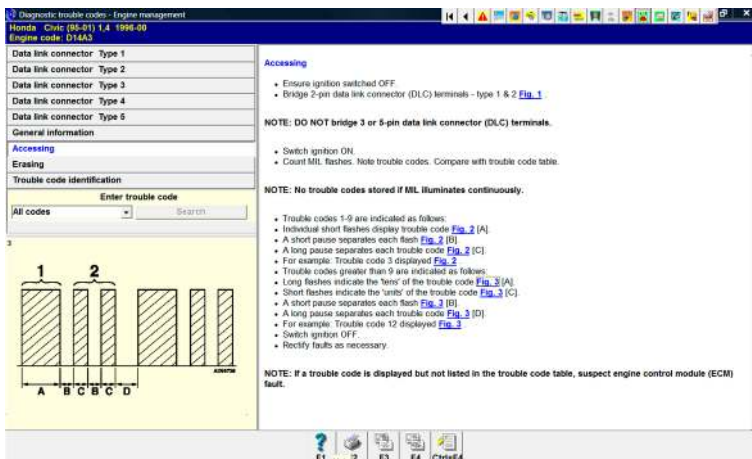

on a piece of paper. Now, we can return to the left column of the page and select Erasing or deleting. Clicking this option a new page opens where we find the instructions for DTC removal on the right side of the page:

Finally, like all other jobs when they are done, they look simple and easy. However, finishing diagnostics

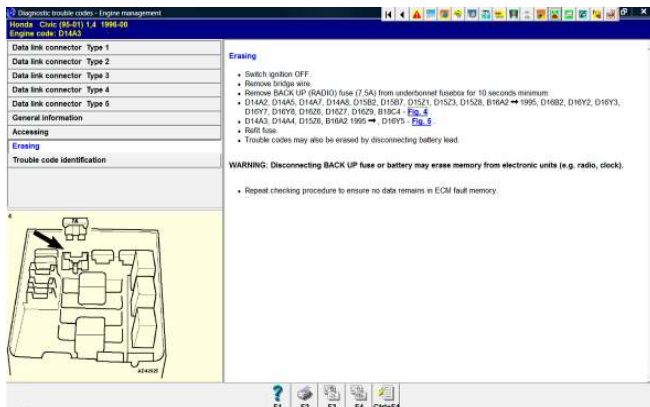

and erasing DTC we have not solved the problem nor do we know where the problem lies. Therefore let's move further on to decipher recorded codes. On the left side of the shown window, choose the option Trouble code identification. The newly opened site contains a list of DTC definitions.

Suppose that we have read the above mentioned diagnostic trou-

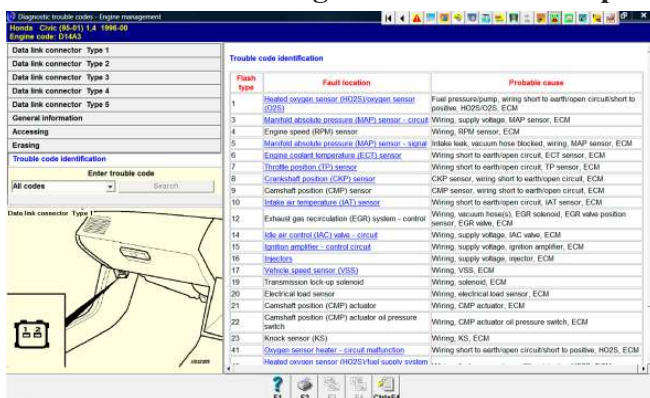

ble codes 3 and 12. In DTC definition list under number 3 we see the problem related to the MAP sensor, but not the advice to replace it. So, now we are back on knowledge. This definition gave us only the orientation to the sector of possible problem. To be certain that we are properly eliminating exist-

ing problem without unnecessary expenditure, it is necessary to know what the MAP sensor is and how it works. The DTC description points to the possibility of problems with the wirings, connector and sensor itself or even the engine computer. So if we have learned

from previous books how the sensors work, we will be able to test the sensor itself as well as the power supply. After we carried out all possible checking, we can conclude with great certainty where the problem lies. Similar case is also with a code 12 which indicates a problem with the EGR valve. And here we get only the orientation about the problem, because the problem may lie in the wiring,

vacuum hoses, EGR solenoid valve, the valve position sensor, EGR valve or finally in engine computer. Therefore, we need to know how the EGR valve works, to be able to determine with certainty where the problem lies. This diagnostic procedure clearly shows how diagno-

sis of vehicle's electronics management, with the device or without it, is not a magic where we can point out the problem with the finger and say: this is the part which has to be replaced. In other words, only after the diagnostics is performed, the right knowledge comes to the fore. Certainly there are



cases where the problem is solved by changing certain elements, but I would classify such cases into the lottery game, rather than professionally performed work. But if we still want to perform our job professionally before we bring our self and customer in an unenviable position regarding possibility of unnecessary and non small investment in repair which is caused by changing parts in the order of elimination until the error is removed, we will use these databases which provide information of each element value during the testing. For example, in the trouble code line number 3 we have the possibility of entering the MAP sensor page by clicking on the highlighted text and find the description of error. By selecting this option, we will find the sensor testing description and all sensor values which we have to obtain during the test. Just

like with diagnosis, and here we find the instructions and drawings for sensors testing. Sentences are short and relatively easily understandable. The sequence is very similar to the preceding. Check the power supply: turn ignition off, unplug the connector from the MAP sensor, turn ignition on, check voltage between terminal 1 and the earth, check the voltage between terminals 1 and 2. In both cases, the voltage should be about 5 volts. Check the MAP sensor signal: turn ignition off, do not disconnect connector and approach connector terminals with voltmeter from the outer side, switch ignition on, check the voltage between terminals 1 and 2 whose value should be about 3 volts. So verifying power from the engine computer and the sensor signal voltage, we can easily guess whether the problem is associated

Engine management Component testing  
Honda Civic (95-01) 1.4 1996-00  
Engine code: D14A3  
System type: PGM-FI

Service adjustments  
Fuel system  
Intake system  
• Throttle position (TP) sensor  
• **Manifold absolute pressure (MAP) sensor**  
• Intake air temperature (IAT) sensor  
• Idle air control (IAC) valve  
Ignition system  
Engine sensors  
Emission control system  
Control system  
Vehicle sensors

Manifold absolute pressure (MAP) sensor  
Checking supply voltage - Fig. 7

Technical Data	
Terminals	Voltage
1 & earth	5 V approx.
1 & 2	5 V approx.

- Ensure ignition switched OFF.
- Disconnect MAP sensor multi-plug.
- Switch ignition ON.
- Check voltage between harness multi-plug terminal and earth.
- Check voltage between harness multi-plug terminals.

Checking signal - Fig. 7

Technical Data	
Terminals	Voltage
2 & 3	3 V approx.

- Ensure ignition switched OFF.
- Do not disconnect multi-plug. Access MAP sensor multi-plug terminals.
- Switch ignition ON.
- Check voltage between multi-plug terminals.

7

AD07078

F1 F2 F3 F4 F5 F6 F7 F9 F11 Ctrl+F4 Ctrl+F8

with the sensor, wiring, connector or the engine computer. DTC 12 in this database does not have a test description as it was the case for MAP sensor, but if we go back to the EGR valve chapter in our book *Automobile electronics & 4-stroke engines*, we will be able to make very quality valve, sensor, and wiring tests.

Described diagnosing procedure without the use of diagnostic devices is identical in all types of vehicles. Of course, every type of car has a different terminal bridging. That's why we need instructions for a particular model that has data access from the computers in the described manner. How to know which vehicles can be diagnose this way? For this kind of information it is necessary to have one of sketched data, workshop manual for particular vehicle or with a little effort information can be found over the Internet. This last method is a bit complicated, but perseverance is often rewarded. When using the Internet, it is always recommended to consider the usage of closest key words to find what we are seeking. Let's say that we are trying to find a workshop manual to diagnose Honda car without the diagnostic device. Appropriate key words would be: How to access DTC on Honda by MIL or how to access error codes using MIL lamp on Honda vehicles. These and similar concepts, will surely lead us to a title in which we can find the instructions we need. Surely, such

process is sometimes time consuming and laborious, but with a lucky hand, it may happen that at first attempt we get the right information. Frequent use of Internet to obtain the required data, will leave a positive mark in terms of memorizing professional terminology which will spontaneously very quickly get into the everyday's use of professional expression.

As we saw at the beginning of this chapter, when choosing a diagnostic failure, in addition to the engine management we are offered the option of diagnosing failure of ABS and SRS *Supplemental Restraint System*, whose translation could be: an extra stop system linked to existing, referring to already installed seat belts. Well, let's now perform diagnostics on air bag system in the same vehicle.

### *SRS diagnostics without the scanning device*

Getting back to the menu, we shall now select the option *Airbags*. After new page is opened, a new menu is offered with general data on the top. On the right hand side we can notice instruction to perform diagnosis without the scanner and reading DTC again by counting MIL flashings, in this case SRS MIL light, while in the lower left corner we see the position of the connector, or DLC, for diagnostic scanner. Moving to the next page by clicking on *Accessing Trouble Codes*, we find the instructions to access information from

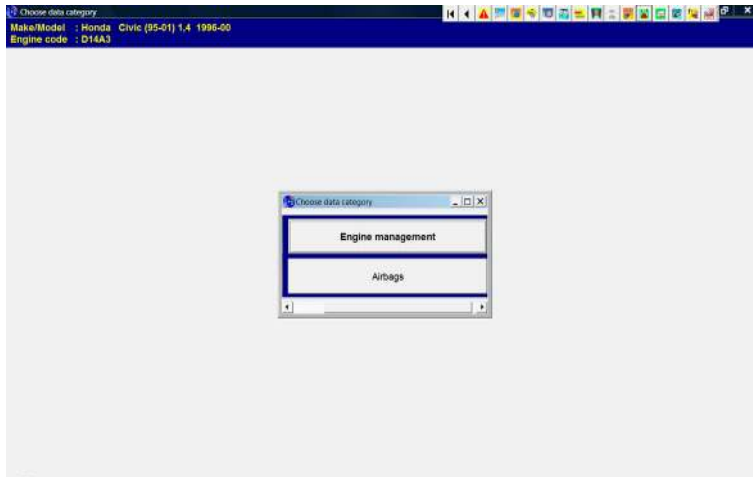

module or SRS computer, and on the left side we can see the drawing how to bridge the terminals. Here is the procedure of diagnosis on the right side of the page: turn ignition OFF at least for ten seconds, find the connector (sketched) with two terminals, bridge the terminals, switch ignition ON, the SRS light flashes six seconds, if there is an error MIL starts flashing, write down the number of flashings and

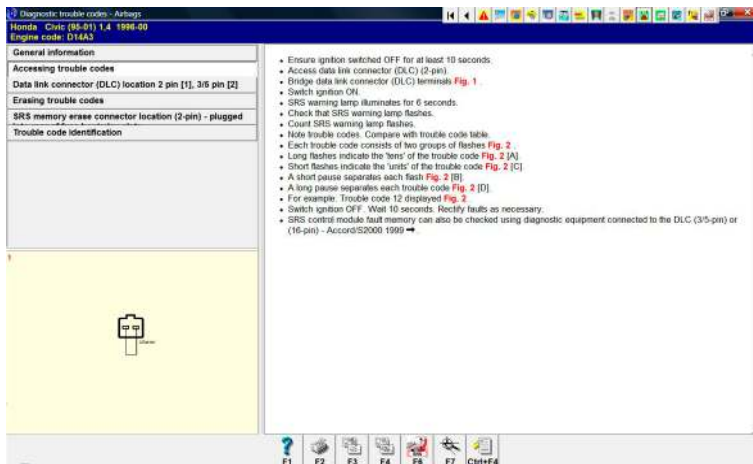

compare them with the codes on the list. Each error, or DTC, consists of two groups. Long flashings indicate the tens and short ones single numbers. Short pause separates

flashings, long pauses are separating codes. As an example, code 12 is shown in the sketch in the lower left corner. Finally, turn ignition OFF for ten seconds and remove the bridge wire (jumper). Module or SRS

computer can also be tested by diagnostic device connected to DLC.

Now we can proceed with erasing stored codes by clicking on the option *Erasing Trouble Codes* and following the instructions: turn ignition OFF, find two pin SRS connector to delete the stored data (sketched in the left corner of the page), bridge the terminals, switch ignition ON, the SRS light flashes six seconds, remove bridge wire

within four seconds after MIL is turned OFF, the MIL lights up again, bridge the connector terminals again within four seconds, light goes out, remove the jumper within four seconds after the MIL turns OFF, light flashes

twice and errors are eliminated from the SRS module, turn ignition OFF.

Finishing diagnostics procedure we can proceed with a definition of



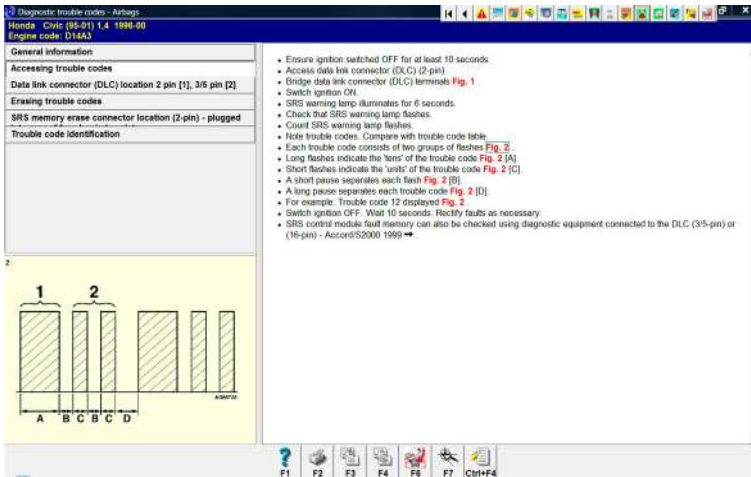

trouble codes by switching to *Trouble Code Identification page*. On the right side of the page we

lies. Thus, we have to check the contacts and the wiring of the driver airbag unit. If that does not

connector, the airbag unit or the SRS module. As we see in the description of the code, there is only an orientation to the problem but does not give a much of advice. But, at least we know in which bush the rabbit

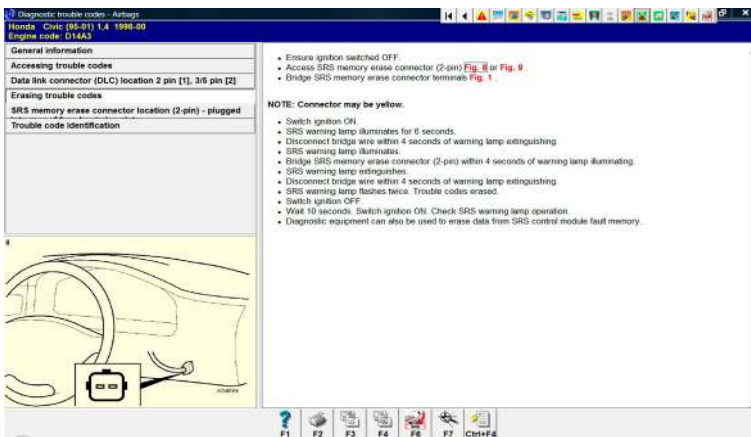

encounter a noticeable problem, we can move on to test the air bag unit. Knowing that the airbag is activated by electric igniter, we can assume that there is some resistance on air bag unit terminals, but

look for read DTC number 12 and interpret the definition which says: great resistance on the driver's airbag. The problem may be related to the wiring or

NOTE: Vehicles without passenger's airbag use a dummy resistor connected to the passenger's airbag multi-plug.

Trouble code	Fault location	Probable cause
11	Driver's airbag - open circuit	Wiring, driver's airbag, SRS control module
12	Driver's airbag - high resistance	Wiring, driver's airbag, SRS control module
13	Driver's airbag - short circuit	Wiring, driver's airbag, SRS control module
14	Driver's airbag - short circuit to positive	Wiring, driver's airbag, SRS control module
15	Driver's airbag - short circuit to earth	Wiring, driver's airbag, SRS control module
21	Passenger's airbag/dummy resistor - open circuit	Wiring, passenger's airbag/dummy resistor, SRS control module
22	Passenger's airbag/dummy resistor - high resistance	Wiring, passenger's airbag/dummy resistor, SRS control module
23	Passenger's airbag/dummy resistor - short circuit	Wiring, passenger's airbag/dummy resistor, SRS control module
24	Passenger's airbag/dummy resistor - short circuit to positive	Wiring, passenger's airbag/dummy resistor, SRS control module
25	Passenger's airbag/dummy resistor - short circuit to earth	Wiring, passenger's airbag/dummy resistor, SRS control module
31	Pyrotechnic pretensioner, driver's side - open circuit	Wiring, pyrotechnic pretensioner, SRS control module
32	Pyrotechnic pretensioner, driver's side - high resistance	Wiring, pyrotechnic pretensioner, SRS control module
33	Pyrotechnic pretensioner, driver's side - short circuit	Wiring, pyrotechnic pretensioner, SRS control module
34	Pyrotechnic pretensioner, driver's side - short circuit to positive	Wiring, pyrotechnic pretensioner, SRS control module

what is its value? The resistance value has to be found in the manufacturing literature, workshop manual, or again over the Internet. When we find the value of resistance, we can verify it with assistance of Ohm meter. If the measured resistance value significantly differs from the specified, the problem lies in the air bag unit.

In both diagnostic cases we jumped to the DTCs erasing procedure before we solved the existing problems. It is quite obvious that failure has to be eliminated before deleting

DTC from memory, otherwise it will appear again. But sometimes there are trouble codes memorized in module's memory but we can not see that there is anything wrong with engine or other systems electronic management. In such cases, we can erase DTCs and see if the same will occur again. In fact, sometimes the DTC is saved due to some other circumstances while driving, and how it appeared so it disappeared. However, the computer registers a problem, regardless of its duration and never deletes it by it self. Therefore, if we doubt the existence of a fault, regardless of the stored errors, we can erase DTCs, and after a short drive repeat the diagnosis.

### *ABS diagnostics without the scanning device*

The problem with the ABS MIL which illuminates because of malfunction of the ABS system can also be solved in a similar manner as the previous two on this vehicle. If we select option *ABS Component*

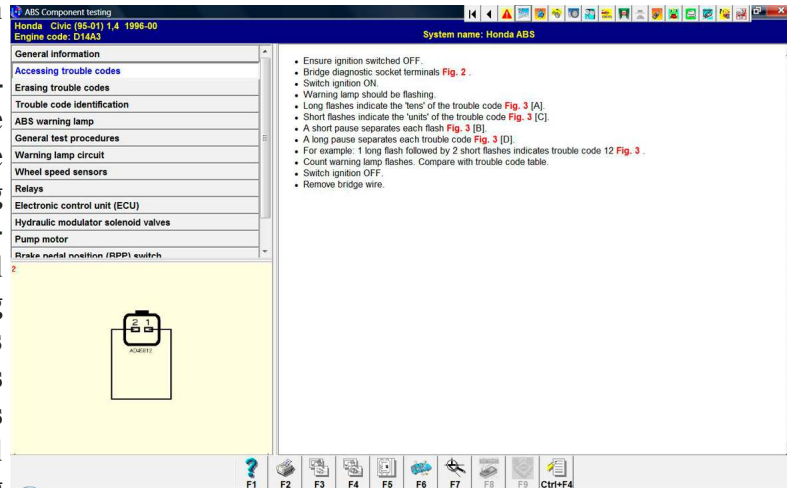

*Testing*, the program will show us a menu similar to previous with the instructions of the availability to access the codes without the use of diagnostic devices. In the option *Accessing Trouble Codes* we follow the instructions: turn ignition OFF, bridge the terminals (sketched), switch ignition ON, ABS light starts flashing, longer flashings indicate tens and short single numbers, short pause separates flashings and long ones error codes, longer flash followed by two short ones indicate DTC 12 (sketched), write down read codes, turn ignition OFF and remove jumper.

Deleting codes: turn ignition OFF, bridge connector terminals 1

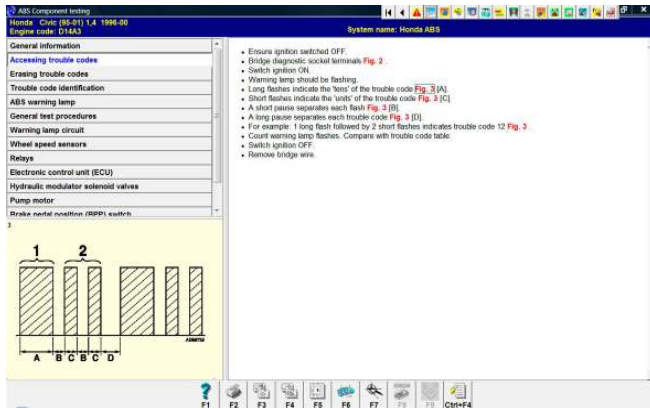

and 2, press the brake pedal and hold it pressed, turn ignition ON, hold the brake pedal pressed until ABS light goes out and than release it, wait until MIL turns on again, press the brake pedal and hold it down, wait until light goes out and release the brake pedal, wait five seconds, the MIL flashes twice and errors are deleted, remove jumper.

If we move to the next option

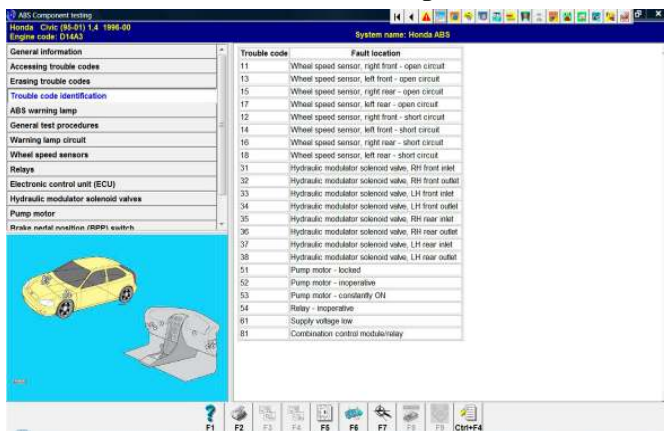

*Trouble Code Identification* and look up the definition of code 12 which we read, it is immediately noticeable that this error is easily solvable. The code definition indicates a short circuit in ABS sensor of the front right wheel. With such clear definition, most will immedi-

ately proceed with sensors replacement, and the problem is solved. But those little pedantic, will make a sensor test before replacement. Namely, as already mentioned, we should never fully rely on the codes definitions to make final diagnosis, which may be wrong and

expose the customer to unnecessary costs as well as bring us in an uncomfortable situation. In this case, rather than having problem with the sensor, there may be a problem in wiring or sensor's connector which is short connected for a number of possible reasons. That's why precautionary checks have to be always made, especially if we have access to data as we have in this database. On the at-

tached sketches we see the option of checking the ABS system elements, or in this case the sensor. The sensor resistance whose value on this vehicle is between 750 and 1050 ohms can be measured on the module connector terminals, connecting the instrument to the marked ter-

minals. However, such checks do not exclude a potential problem of short-circuit on sensor connector or its wiring. Therefore it is advisable to measure the resistance at the terminals of the sensor located on the wheel hub. Only if we found no resistance on the sensor termi-

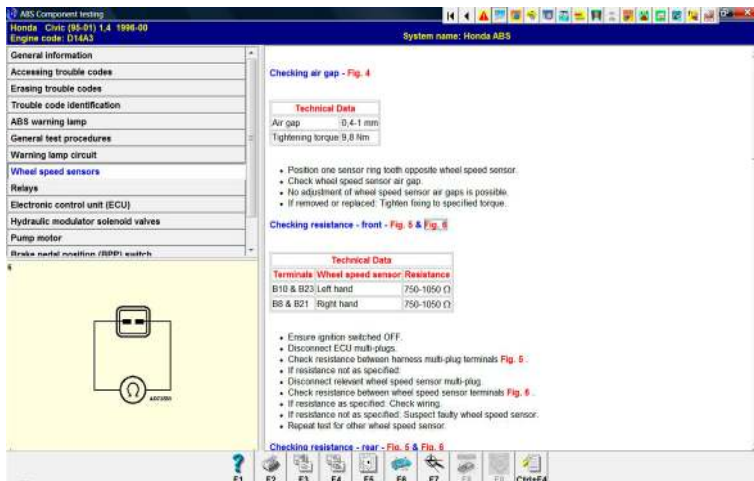

nals, we can conclude that there is a short circuit inside the sensor and replace it.

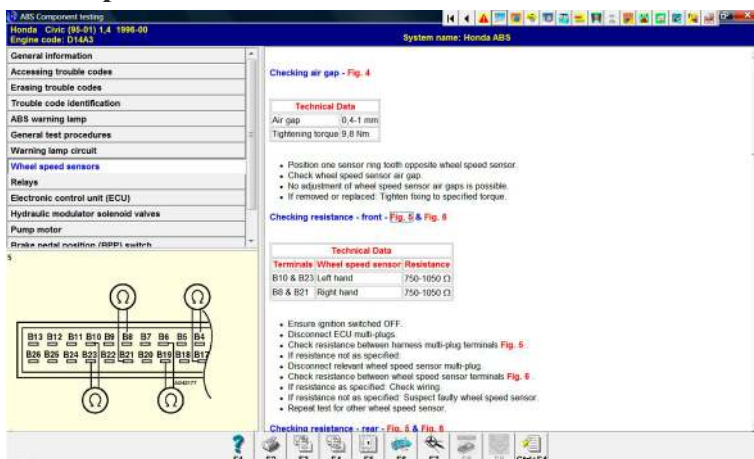

### Resetting service intervals without the use of devices

Beside the possibility to perform diagnostic operations on hundreds car models without the use of diagnostic devices, by using these databases we can also reset service intervals on most of them. Here is shown example on BMW 3 Series (E36) 1.6 316i year 2000. After selecting a vehicle's brand and model we choose the option *Service Indicator* or a similar topic on dif-

ferent types of cars. On the left side of the page, diagnostic connector drawing is visible with marked terminals. Above the drawing, menu offers options to reset the oil service warning light, inspection service

warning light or all service warning lights in the package. So, let's select this reset in package by

clicking the last option and follow the instructions: switch ignition ON, connect a test lamp between terminal 7 and the ground (ground is anywhere on the metal part of the body or engine), after 12 seconds five green LEDs

will illuminate on instrument panel, turn ignition OFF, wait twenty seconds, switch ignition ON, reconnect the test lamp to terminal 7 and ground, after 12 seconds all five green LEDs on the instrument panel will illuminate again, turn ignition off and reset is complete.

Ability to access data stored in the modules or computers memory as described enables us to engage in repair and to deal with problems on hundreds of car models



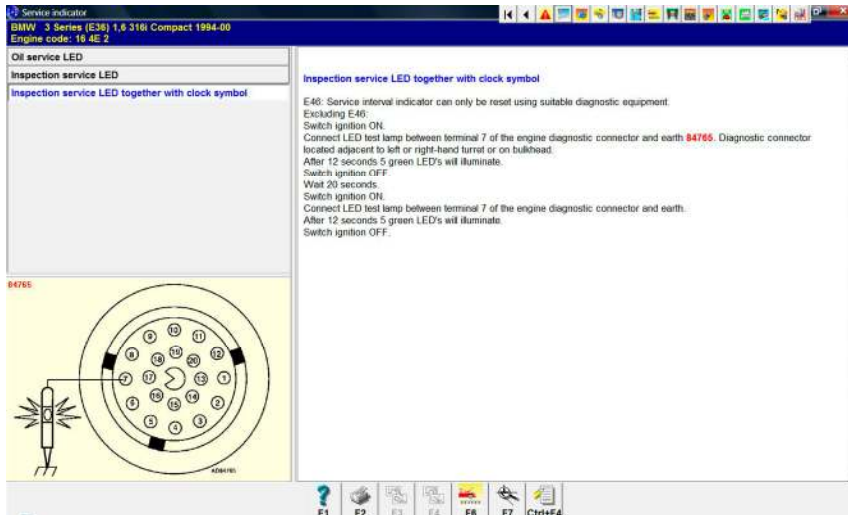

*On Board Diagnostic* means that engine and other system computers have the ability to diagnose faults of electronic management of the

without the a number of expensive diagnostic equipment. These options should not be ignored even when it comes to cars for which we suspect not to be able to handle tests without a diagnostic device, but there are always surprises even when we least expect them. Therefore, always check if there is a possibility to do diagnostic or reset service intervals without the use of scanning devices.

### ***OBD I***

#### ***Diagnosing failure with diagnostic device***

In this chapter, let's start with instructions and examples using OBD I diagnostic devices and related software. As it has been already mentioned in the book *Automobile electronics & 4-stroke engine*, OBD diagnostic system is divided on OBD I and OBD II. Repeating already read text, in most cases it is very useful. Therefore, let's say one more time that OBD

entire car by them self. Of course, every computer or module does it for certain system. It also means that the engine, ABS, SRS, AC and other systems have a separate module which is often called the *Electronic Control Module ECM* and control particular system on vehicle. Although the modules or computers are separated and responsible for managing the system and diagnosing faults in their system, they can be connected if they interact. For instance, the ECU *Engine control unit* in newer cars is associated with the ABS module. The interaction of these two modules is necessary on vehicles with embedded ESC *Electronic Stability Control* system. ESC as a separate system has installed own software in its ECM. However, ESC can not control the vehicle stability if it does not use the ABS system. Therefore, ESC module is associated with ABS module. However, vehicle's stability is not controlled only by ABS, but if necessary, engine power is reduced in critical

situations, and therefore ESC module is associated with the ECU too.

In older cars models, the modules are not interacting, and they are separate and independent of each other. For this reason, sometimes we need specific diagnostic devices to access data stored in each device module. It is not uncommon, that each module has a separate connector for specific scanner. Such an example, we had a chance to see on the Honda Civic when we had performed a diagnostic test without the use of diagnostic device. To access the engine data we used DLC *Data link connector*, or connector for accessing data which is located on the left below the instrument panel, and for SRS data access we used the second connector located behind the handbrake lever. Thus, these are two completely separate and independent systems. Because of the impracticality of such separately located and different DLCs or connectors, over the time, car manufacturers increasingly practiced installing multi-pin connectors through which accessing data from different ECUs becomes much easier. However, regardless of the joint connector, not all scanners can read data from all modules. If we had the scanner which reads the engine module, the same could not read ABS or SRS module. Complete reading could do just more expensive and complicated devices with installed software for each system and built-in

protocols. Under the protocols, we understand the wire or terminal connections between the scanner and DLC or diagnostic connectors.

To have the clear picture of protocols, it is necessary to know the following. Each module has a K-line through which information are collected and the L-line which stimulates the module. Therefore, if we have a diagnostic device, more known as a scanner, with K-line to access data from the engine module, the same is not able to get data from the ABS module, even if we have installed program to read data from ABS module. So, to have a scanner which could read the data from multiple modules in the vehicle, we need to have programs for reading these modules and scanner's K-line associated with the K-lines in all modules through the DLC. This kind of diagnostic devices, or scanners, complexity, which can perform multiple functions have much higher price than those provided for reading data from only one module in particular vehicle. Even these more complex scanners do not cover all vehicles, but one or two groups or car models. Since the protocols are not standardized, nor the programs, it is extremely difficult to produce a device that would cover all types of cars and all the modules installed in them. Knowing that almost nothing is impossible, and the production of such a device is possible, but the issue is cost. Manufacturers of diagnostic equipment came to a sim-

ple conclusion. Larger services are often specialized for particular brand or group of car manufacturers. Such services are mostly specialized in vehicle group: VAG, Fiat-Lancia-Alfa, Rover-Jaguar, Mercedes-BMW, etc. Therefore, we can find on the market highly complex diagnostic devices covering a particular group of cars at reasonable prices. Smaller services due to the lack of work are doing all types of cars and would not be able to pay such a high price for universal diagnostic device which would cover everything. That is why such services are generally equipped with limited purpose universal devices and additionally purchasing other scanners for a particular brand or group of vehicles.

### *K and L diagnostics lines*

In car diagnostics K-line is the single core wire for data transmission in both directions and has a standard labels ISO 9141 and ISO

14230-1. In combination with L-line, in car diagnostics K-Line has a capacity for information to flow in both directions, collecting and sending information in the same time. In accordance with the stan-

dards, L-line has only a function of ECM stimulation. Stimulation or initialization (start / impulse) with separate L-line is usually used on older devices, while the newer scanners solve initialization via K-line. Property of two-way communication via K-line with a single wire can not function simultaneously. Only after the data is transferred in one direction, it is possible to transfer data to another.

The attached sketch shows the schematic diagram connecting the diagnostic device with the ECU in two ways. The first ECU is connected only with the K-line which initializes the diagnostic procedure by sending data of the diagnostic device, and then collects and sends data. Second ECU is connected with the L-line to initialize and the K-line to collect and send data. Because of clarity, this is a simplified sketch without the power and

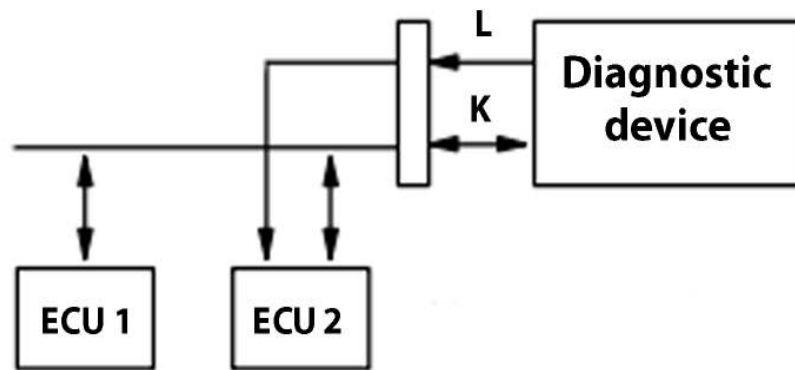

ground connections.

As shown, connection has been done only with the K-line of ECU or engine computer, and only the engine data will be available. Complex diagnostic device connection

(protocols) with multi-pin diagnostic connector can be seen on the following sketch. Here is shown diagnostic connector of Opel car model. In the first case the vehicle is manufactured between 1988. and 1996. for U.S. market. On the models made for the European market, these kinds of connectors we will meet until the year 2001. The terminals on the connector are labelled alphabetically, and the

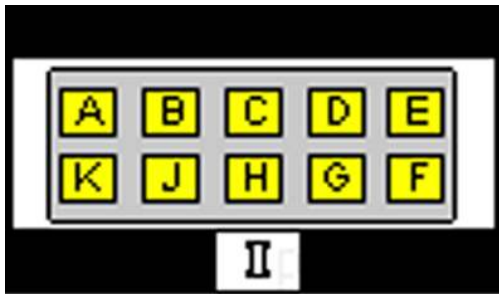

Pin Number	Name	Description (may be empty)
A	GND	Ground
B		Slow self-diagnostic codes. Engine diagnostic K-Line.
C		Automatic transmission slow self-diagnostic codes. Transmission diagnostic (L-Line).
D		Trip computer slow self-diagnostic codes. Engine diagnostic K-Line.
E		Slow self-diagnostic codes out.
F	+12V	Accumulator +12v
G	K-Line	Automatic transmission, engine, ABS diagnostic
H		Cruise control, ATWS slow self-diagnostic codes.
J		4WD slow self-diagnostic codes.
K		ABS slow self-diagnostic codes. ABS L-Line.

following table shows what is connected to each terminal. Thus, terminal A is the ground, F is the power supply terminal for interface (or scanner) connected to a PC or laptop. The use of different terms for the diagnostic devices is done on purpose, because we shall meet such different terms going through the various literature and

programs, what could be confusing if we do not know what it is. As already said on several occasions, none of these scanners is diagnostic device, because ECM does diagnostics itself. We only have access to information from the ECM by the specified devices and programs which allow us communication between the ECM and a home computer. Definition of interface: a program that allows us communication between the two, for example, devices. Under the letter G we see the K-line connected with automatic transmission, engine and ABS module's K-line from which we can obtain all data, while other terminals are provided for other modules.

In the next case, we see far more complex OBD II diagnostic connector with terminals labelled by numbers from 1 to number 16 (standardized number of terminals on the OBD II connector). In the table that follows we can see what is connected to the OBD II connector terminals. Power supply for interface on the terminal 16 and ground on terminal 4 is standard on all OBD II connectors, while connections on other connector terminals vary depending of vehicle model (protocols). This second table significantly clarifies previous text associated with the



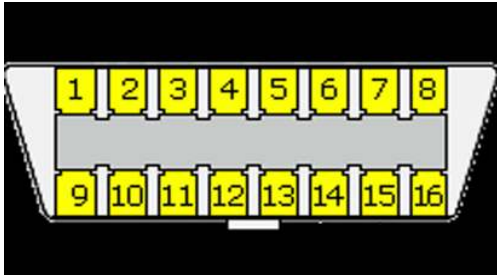

Pin Number	Name	Description (may be empty)
2	K-Line	ABS diagnostic
3	K-Line	Radio, automatic transmission, immobilizer, steering wheel and other components
4	GND	Chassis ground
5	GND	Signal ground
6	CAN-High, J-2284	If car isn't equipped with CAN bus, you'll find self-diagnostic slow codes (e.g. on Astra-F-G) or ABS K-Line at this pin
7	K-Line	Engine, ABS, AT, Airbag, Navigation system, Radio diagnostic
8	K-Line	TID, MID diagnostic
9	K-Line	ABS, Airbag
11	K-Line	Automatic transmission diagnostic
12	K-Line	TID, MID, ABS, AirBag, air conditioner, Kuhlerluefter-Steuergerat
13	K-Line	immobilizer, MID, Airbag diagnostic
14	CAN-Low, J-2284	if CAN present
16	+12V	Accumulator

from other modules, interface has to be connected to the K-line of each module and then we can have data access with appropriate programs. But if we work only on OPEL cars, we can certainly afford a multi-function scanner

which will have the software installed to read all the modules and interface adapted for the initialization of each module, along with the multiprotocol connector or connector that connects all K-lines terminals with the interface.

**K-line.** At Terminal 2 we see the ABS ECM's K-line, and at the terminal 3 common K-line which is associated with the modules of radio, automatic gearbox, immobilizer, steering wheel and other additional components which can be incorporated into the vehicle. Furthermore we see specifically derived K-line for complex diagnostic procedure of ABS, automatic transmission, SRS, etc.

If we try to diagnose this vehicle with an OBD II scanner for engine diagnostics only, we will access data from the engine module via the CAN protocol at 14<sup>th</sup> terminal. As we can see, to read the data from other modules, we have to have an interface which will connect with the K-line of these modules. Other words, to read data

### *KL diagnostics*

As function of K and L lines has been explained, we can proceed with the diagnosis using the KL interface. This type of diagnosis is applicable on cars manufactured before 2005<sup>th</sup> when diagnostics is switched to newer, faster protocols. Protocols which standardize and support the KL diagnosis are ISO9141 and ISO14230. This second protocol is also known as KWP2000.

In order to begin the process of diagnosis, we need a KL interface which is usually connected to a computer via a 9-pin serial port which is the most reliable data transmitter. The same interface can be also found with a USB port

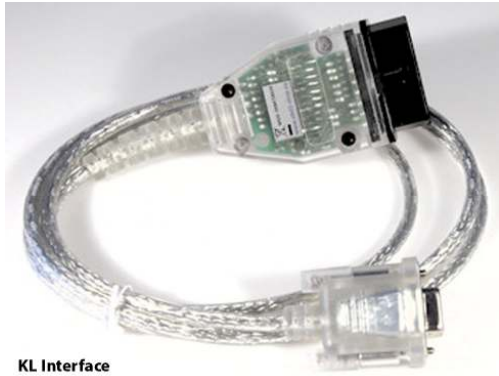

KL Interface

connection. However, with USB connection some problem may occur during diagnostic procedure with KL interface, because the programs that we are using are mainly the older generation and are designed to work over the serial port.

Beside the interface, we need programs to read data. If we buy a factory made interface, drivers are usually found in the package which enable interface to operate in Windows, and at least one diagnostic program for certain group of vehicles, most often VAG cars. Since the KL diagnostics can diagnose a whole range of cars, we shall require programs for other vehicles too. Beside the possibility to purchase commercial software, we can download a number of them over the Internet as freeware. If we do not have the name of the program that we are looking for through the Internet, or Web address from which we can download, this key words may help: KL diagnostic freeware, KL Opel diagnostic freeware, OBD freeware ...

In the interface shown in trans-

parent plastic, we can see an electronic circuit which enables secure communication between the ECM and computer. On the other side of the cable we see the 9-pin connector which has to be plugged into the computer's serial port. When the interface is connected to the computer, we get notification in new window that new hardware has been found and request to install it. After we select Yes, it is necessary to insert supplied CD with drivers. Finally we select the option automatic installation and the interface is ready for use.

As seen on photo, this KL interface has OBD II connector and it can not be used on cars with OBD I diagnostic system. Suppose that in this case we perform diagnostics on VAG vehicle. We know that the OBD II diagnostic system on cars with gasoline engines is found only in those made since 2001. and very rarely on some earlier models. However, it is not uncommon on older models to find the OBD II connector, but OBD I diagnostic system. Therefore, this scanner is sold with OBD II connector which is most commonly installed in vehi-

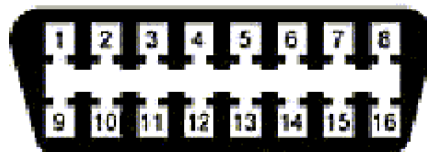

- 4 - Ground / Masse
- 7 - K-Line
- 15 - L-Line
- 16 - +12 (Vbatt)

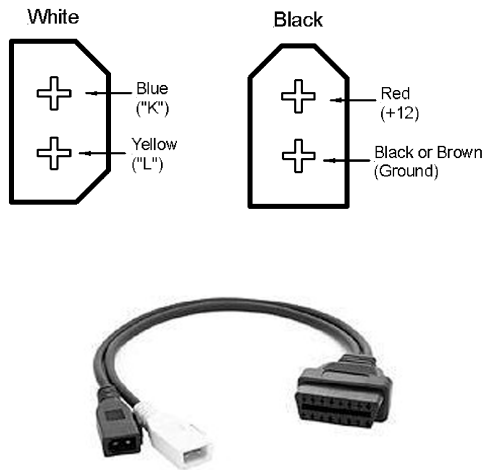

cles. But what to do with the older types of cars for which this scanner is provided?

On the above drawing we see how the VAG older diagnostic connector, located under the bonnet, looks like. First rectangular connector has two terminals K and L-line, and second one 12V and ground terminals for interface power supply. Knowing which terminals on the OBD II connector are K and L lines and which are power supply, we can make adapter with four wires. However, such connection is quite risky as we can easily cause short circuit and have unwanted consequences. Therefore, it is advisable to buy factory made adapter. Such adapter is plugged into the OBD II connector and its other side to the rectangular connectors on the vehicle. With this adapter cable we connected power supply and K and L lines from vehicle to the designated terminals on the OBD II connector.

The sketches show mentioned

terminals on the OBD II connector and on the VAG vehicle diagnostic connectors. It is quite clear now, if we do not have the adapter cable for a particular vehicle, we can always make a connection with the wires. As we saw in previous articles, each vehicle has a different arrangement of terminals, i.e. K and L lines and power supply, if is not the case of OBD II connector on the vehicle. In other words, it would be advisable to obtain original adapter cables for all types of vehicles or just for the common ones. However, if we have to make wire connections, then we have to obtain a diagram of the vehicle's diagnostic connector. Such diagram will be very similar to this with VAG's marked terminals. The sketched OBD II connector terminals are standardized and can be easily remembered, but the terminal markings of older cars connectors should be obtained. Again, one of the easiest ways to find needed diagrams is the Internet. Typing the term i.e. OPEL pinout will certainly result with a number of sketches with marked terminals.

In this case we had a situation where all the information was obtained through the only one K-line. In previous sketches we have seen that some diagnostic connectors have several K-lines. These connectors we will find on Fiat, Opel, Mercedes and some other models. This means that we have to connect K-line, if necessary, and L-line if marked, with the K-line ter-

minal on the ECM with whom we interact. Thus, to test the engine we shall connect to engine's module K-line, ABS to the ABS's module K-line etc. Power supply we can connect to the diagnostic connector marked terminals, or directly on the positive and negative battery terminals.

As we see, on the VAG cars is really not so complicated to con-



**Pinout box**

nect terminals with wires, as is the also case with Fiat and Alfa cars. But, if we have to do such wiring on BMW, Mercedes or some other car models, a matter considerably changes due to the multi-pin connectors. Of course, adapter cables are available for all these vehicles as well as universal OBD II adapter cable with four banana connectors (K and L lines, 12V and Ground) together with so-called Pinout Box.

Let's make one example with an Opel vehicle manufactured 1998<sup>th</sup> with the OBD I diagnostic system and OBD II connector. If we do not have interface for Opel automobiles, standard terminals on OBD II connector will be: 16



**Fiat-Alfa-Lancia adapter cable**



**Mercedes adapter cable**



**BMW adapter cable**

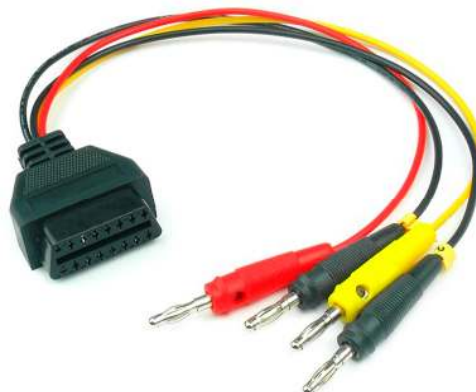

Pin Number	Pin Name	Opel vehicle function
1		n/a
2	J1850	n/a
3		K-Line, K2, TCM, Sunroof, CDL, Multi-Timer
4	GND	Chassis ground
5	SGND	Signal Ground
6	HS-CAN	Blinkcode
7	K-Line	K-Line, K1 (engine)
8		K-Line, K4
9		reserved
10	PWM	n/c
11		reserved
12		K-Line, K3, ABS, TC, Steering, RTD, OW
13		reserved, K-Line, K5
14	HS-CAN(-)	reserved
15	L-Line	n/c
16	Battery+	Battery +, unswitched

Power, 15 L-line, 7 K-Line and 4 Ground. Such a protocol will suit VAG vehicles which have the same terminals arrangement on OBD II connector. This protocol will also suit Opel cars, but only for accessing data from engine module. ABS, SRS and AC module's K-line will be at the terminal 12, while for gearbox and central locking we shall use 3rd terminal. It means if we want to read data from other modules, we have to connect interface's K-line with their K-lines on the vehicle's OBD II connector. It is quite obvious that wire connection in this case is more than inconvenient and awkward. If we use now OBD II adapter with four banana connectors (Red +, Black-, K-Line Blue and L-line Yellow) and Pinout Box (Ground at 4<sup>th</sup> and 5<sup>th</sup> terminals marked in black and the power on 16<sup>th</sup> marked in red), whole process becomes simple. By plugging OBD II adapter into the OBD II connector on the interfaces we shall get four banana connectors (12V, Ground, K-Line and L-line). OBD II connector from Pinout Box has to be plugged into the vehicles OBD II diagnostic connec-

tor on the vehicle and we have got all 16 terminals accessible from OBD II diagnostic connectors. Positive and negative banana connectors have to be plugged into the Pinout Box holes labelled with number 16 and 4. Remaining two bananas we shall plug in holes of K and L lines of the chosen module from the diagram which we previously obtained for particular vehicle. Thus, in the case of our Opel, if we want to test the ABS, we shall see on diagram that the ABS K-line is at the 12<sup>th</sup> terminal. If we have previously obtained an appropriate program for Opel cars, with ignition ON, testing can begin. Throughout this process has remained untold a trifle to which we will look at during the OBD program installation, coordination of communication ports in the program we work with.

### *Installing KL interface and software*

How to install program and interface? Suppose we have just bought the interface and programs on CD. In most such cases people ask for assistance from someone skilled to install the program (Software) and device (Hardware). Therefore, let's pass this procedure step by step. With purchased Interface, beside the drivers for interface installation, we will usually find i.e. VWTOOL program. Insert the CD in the laptop or PC and wait while menu shows up and select the option *Open folder*. In





case that mentioned menu does not open after inserting the CD into the computer, the procedure is as follows. Look on the desktop for My Computer icon. Double click on the icon, and new window will open displaying all computer's disk drives: C, D, E. .. Select CD or DVD drive, clicking twice on it content of the CD will show.

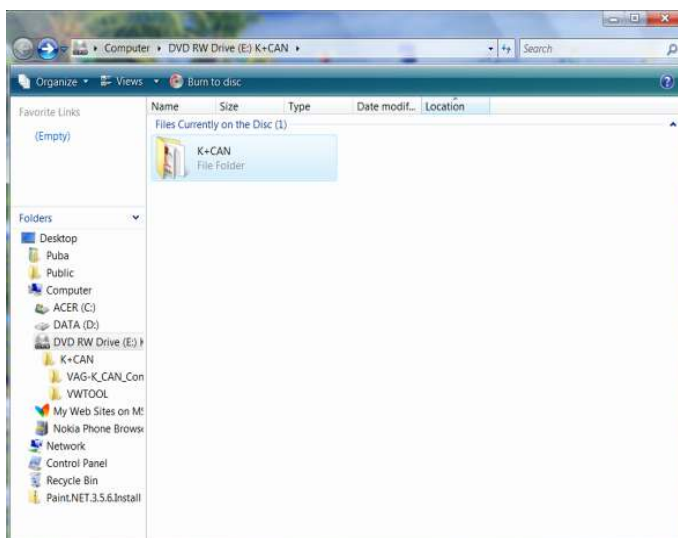

One way or the other we have opened the CD and found the first folder K+CAN. The folder's name itself indicates that we are going to install quality program which supports the KL diagnostics or OBD I and OBD II diagnostics with latest CAN protocol. Clicking twice on that folder, new one opens. In the new folder, among other things, we see the program folder VWTOOL. Double click on that VWTOOL folder and new one will show again. With double click on this last folder we are opening its content and finding *Setup* option. Double click on *Setup* and program installation is activated. If we have an antivirus program installed, it will stop installation and warn us about unidentified program and ask permission to continue with installation. Permit continuation with *Yes* and program installation begins. During the installation program asks specific questions for which we must provide answers. The first question we

meet is whether the program may be installed at the proposed location of the disk C. If not, you we have to enter the location, but in practice programs are always installed on the C drive. By clicking *Continue*, the program continues with the installation. **Oops! Problem.** The installation has started and stopped. New window appears with mes-

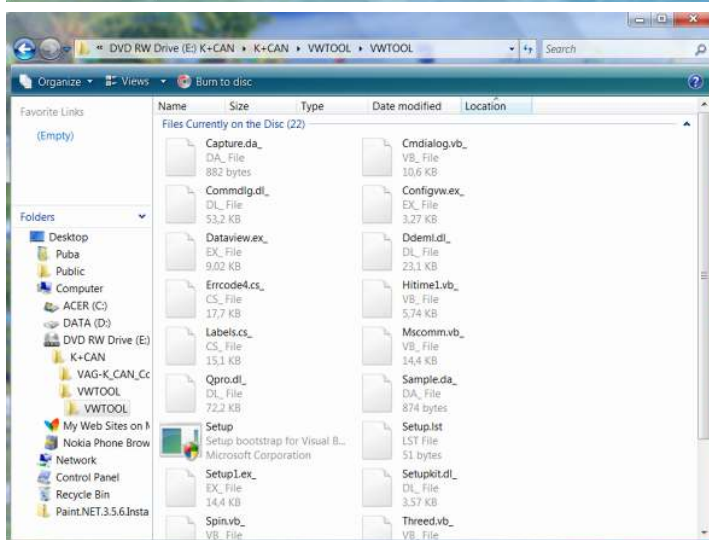
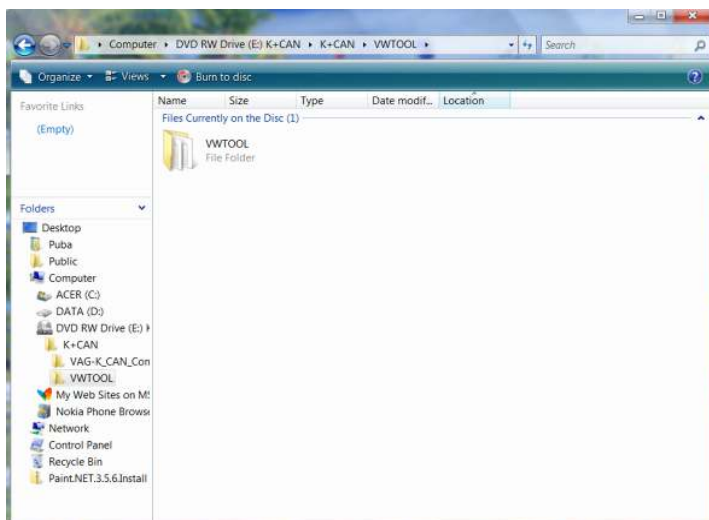
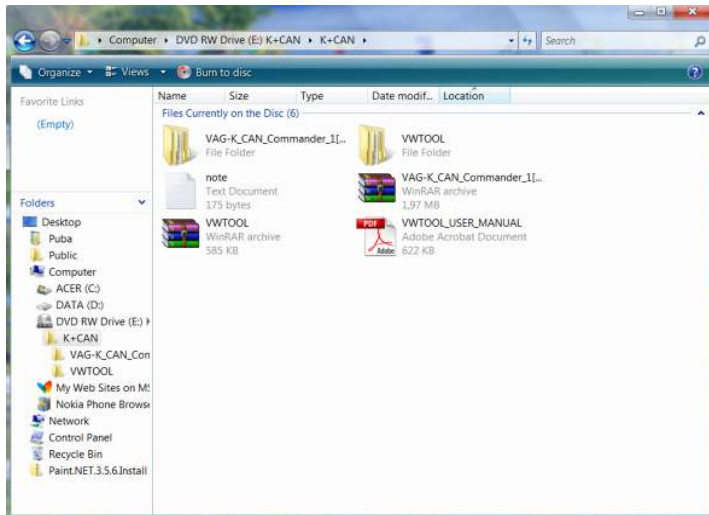

sage that certain components of the program can not be installed. Another two or three attempts were unsuccessful. What is it? Antivirus protection allowed installation but it failed.. The only conclusion is as follows. Here was made attempt to install program on a laptop with Windows Vista. Since this is an older program, it is probably not foreseen for Vista, what is not uncommon for older generation programs. The only solution that remains is the attempt to install program on another computer with Windows XP. So let's try.

We went to another computer and repeated previous procedure. Assumptions were obviously justified. On Windows XP, the program was properly installed. The red installation line which has stopped in an earlier attempt to install the program on Windows Vista passed without stopping from the left to the right side and

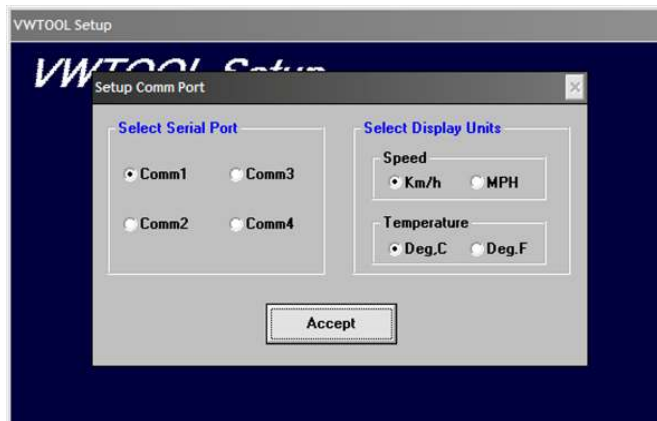
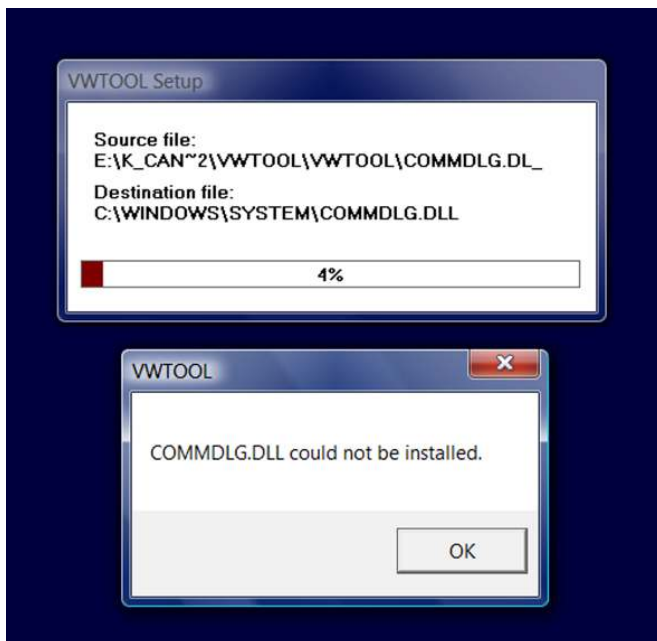

grams offer very limited number of ports, very often from 1 to 4. At that time when such a programs were used, more ports were not needed because the 9-pin serial port 1 was mostly used and automatically suggested. However, with this modified K+CAN interface, which we have just bought, connection is foreseen via the USB port. Knowing that the COM 1 is serial port and COM 2 parallel typically used for printers, we shall choose the port 3 or 4. In our case we have selected the last port 4, for pure precaution if port 3 has been accidentally occupied for some reason. After selecting the port, through which the diagnostic program will communicate with the engine's ECM, or any other, a new window appears with the sentence: VWTOOL installation is completed.

During installation, we are often offered to create a program icon on the desktop. Seeing that this option was not available

completed program installation. Before finalizing program installation new window appears where we have to define interface communication port. The older pro-

during installation, we have to create it our self. To do that, we have to click on *Start* in the lower left corner of the monitor and click on *Programs*. In the programs menu



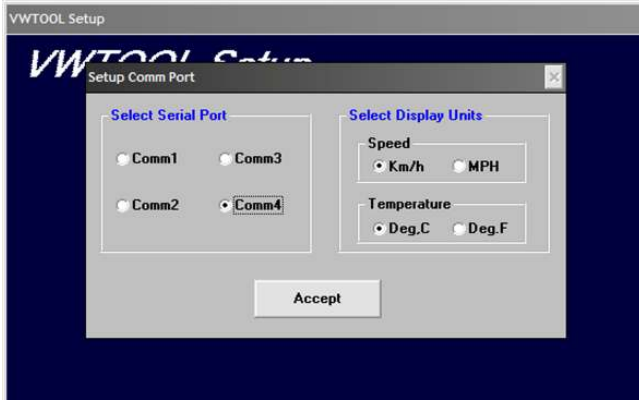

gram icon on the right side. In the right side column, right click on the program icon and choose *Send To* and *Desktop (create short cut)*.

Program is successfully installed, communication port is defined, and we only need the interface to make connection with the vehicle. So, let's start with the interface installation, and prepare our computer for communication with vehicle's modules.

Connect the interface via the USB port to the computer. Shortly after plugging scanner to the computer, new window appears with the message

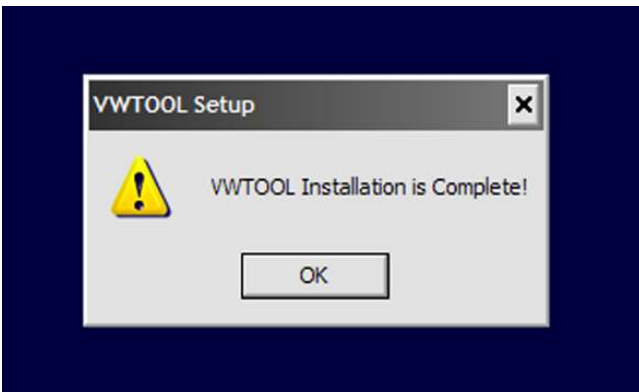

we look for installed VWTOOL. As we go over the program title with mouse, we shall notice pro-

*Found New Hardware*. Automatic installation and *Hardware Wizard* will guide us trough the installa-



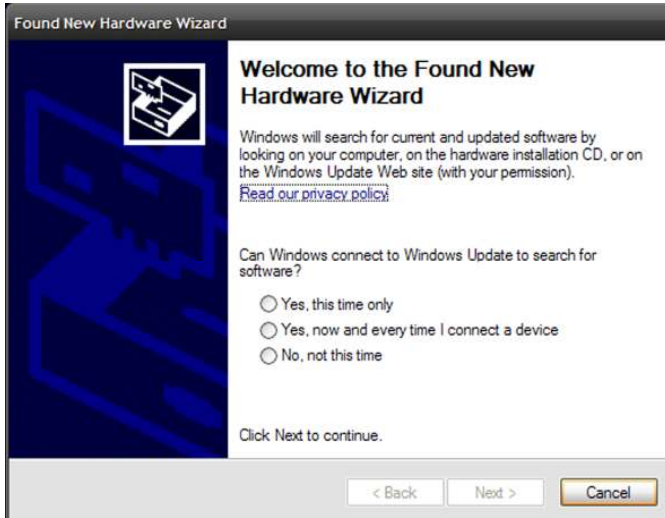
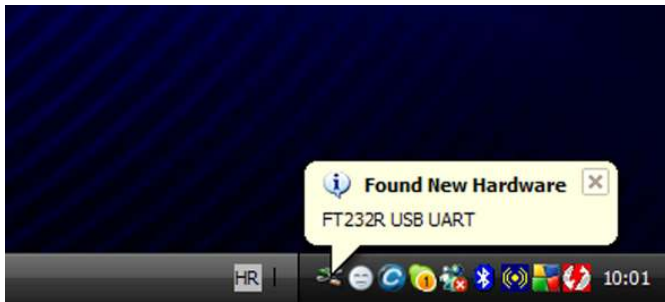

Internet to search for software? Second: Do you want to connect to the Internet each time you connect the device? Third (suggestion): Not this time. In our case we choose the third option because we have the installation program. If we, for any reason, removed the CD from the computer with *VWTOOL Setup* and drivers for interface installation, insert it back into the computer's CD drive. The next window that appeared after we selected the third option on the previous window and clicked on *Next*, offers us the option with automatic installation and manual where we have to specify the location of the installation program. Here we choose automatic installation, in which case the Wizard finds the drivers on the inserted CD. By clicking on *Next* after selecting the first option, we see how the Wizard scans our computer for installation program.

tion process. To find the right track in finding programs and drivers to install the interface, Wizard raises three questions. First: can windows connect to

After finding the program, data transfer follows from CD to the computer. Completion of green line stream in the next window indicates the end of data transfer. Finally we click on *Finish*

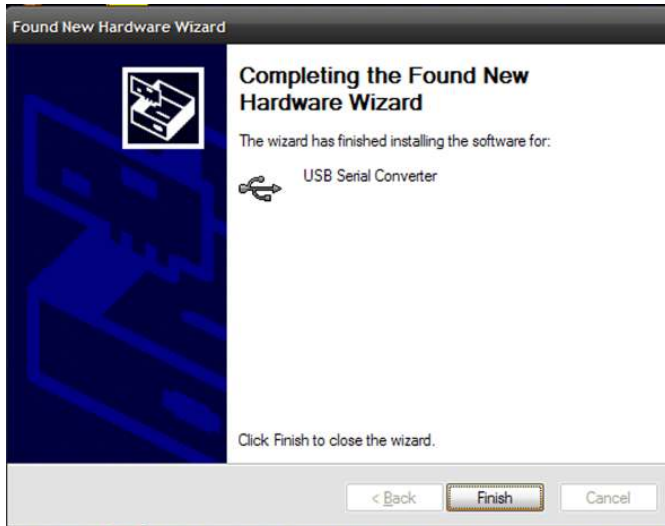
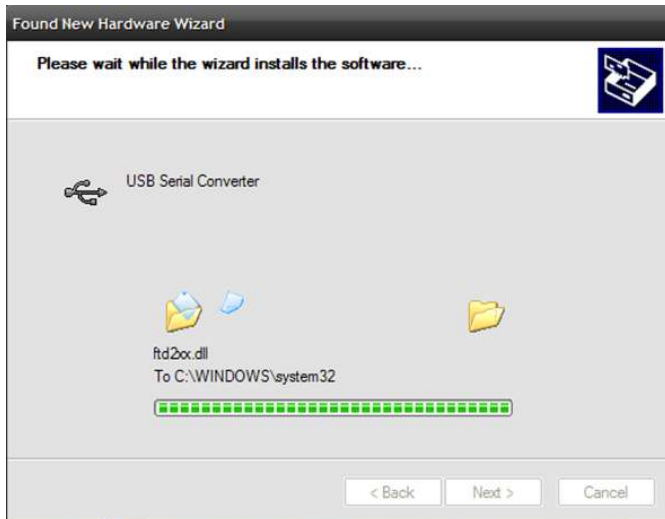

in the next window and the interface installation is successfully completed. However, to make sure that we have connected chosen USB port with a diagnostic program, we have to make the following checks. In the lower left corner of the monitor click on *Start*. In the open menu, select *Settings* that leads us to the *Control Panel* with programs which control computer operations. Find the *System* icon, open the *Hardware* and then the *Device Manager*. In the computer components menu, click the + mark in front of the *Ports (COM & LPT)*. In addition to the physical ports (COM 1) and (COM 2), we see a whole series of virtual ports which are installed when we installed the interface. These ports are usually marked with the acronym USB, but here we see them labelled as Bluetooth ports. The reason is pre-installed wireless OBD II scanner which works over the Bluetooth. If we find on this list the number of USB or Bluetooth port (COM 4) which we have previously defined in the program, the installation

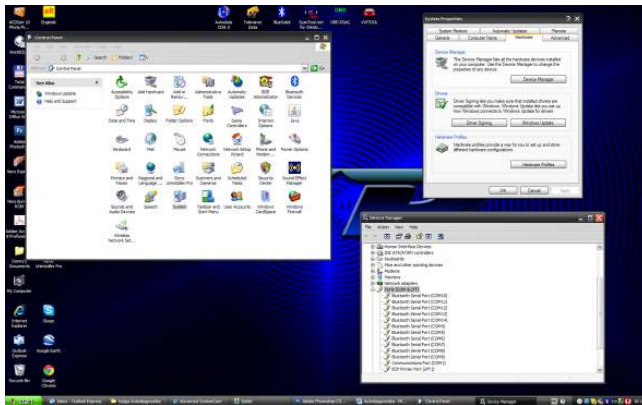

was completely successful and the program will be linked with the interface and the vehicle through the existing fourth port. But if we do not find a port number, which we defined in the program, diagnostics will not work because the program can not find defined communication port for connection with interface. In this case, the procedure is as follows. From the

ing number with number 4 and click OK. Check the ports list again to see if (COM 4) is listed. If the whole procedure is properly done, the program is installed and communication between the programs and interface is harmonized and diagnostics is ready for use.

Just like when any job is done, we can not wait to see the effect of what we did. So let's check it. With this type of interface and K+CAN program, diagnostics can be performed on all types of VAG cars (VW, Audi, Skoda, Seat) combining older models made until 2001<sup>st</sup> for which we are suppose to use KL diagnostics, and models made since 2001<sup>st</sup> for which we use OBD

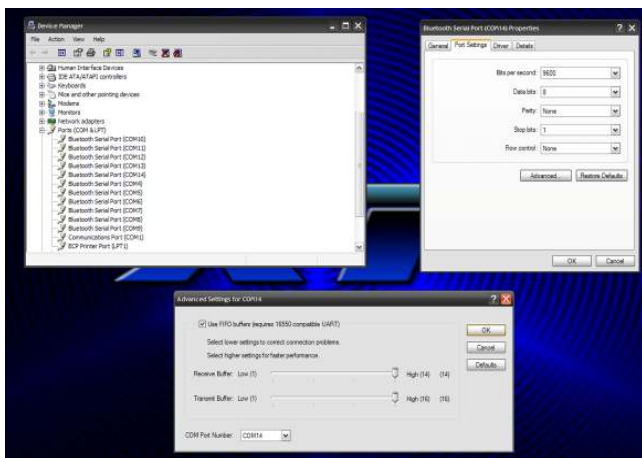

II diagnostics. As known, Interface has to be connected to the vehicle diagnostic connector and ignition switched *ON*. On the computer, double click the program icon, and diagnostic process begins. In the open program's menu we can immediately notice complexity of the program by offered scan options. The upper main

ports list choose one port (9, 12, 16 ..) and right-click on the one of them. When new window opens select the *Port Settings* option. By clicking *Advanced*, new window opens where port number can be changed. In the option *COM Port Number* simply overwrite the exist-

menu gives us the possibility to scan ECMs of: engine, transmission, ABS and SRS, thus the four most important automobile systems. Additional menu provides us with expanded possibilities to scan other vehicle systems: clutch, adjustable suspension, anti-skid sys-





tems, anti-theft system, sunroof, central locking, instrument panel, air conditioning and heating, electric seat adjustment and a high pressure pump on diesel engines. But that's not all. When we click on the *More Modules*, scanning is expanded to additional modules: the car level control, the monitor in the vehicle, the range of the headlights, setting the position of the steering wheel, a module that manages all incorporated devices in the vehicle (*Central Convenience*), or better known as accessories: radio, rear view mirrors, parking system and additional



heaters.

One should be aware of the fact that the diagnostic programs are sometimes very complex, although they simpler programs should not be taken as simple ones. If we would clarify in detail all the functions of individual programs and their capabilities, as well as issues related to read errors, it would certainly take a several thousands pages. This book should provide even more than just fundamentals of diagnostics, but by no means a complete knowledge which is gained by experience and constantly updating knowledge. Therefore, before using a particular diagnostic program, it must be well studied as well as all available literature about it.

Proceeding to use VWTOOL program, we will refer only to the few functions of this program which are very similar to the programs of other vehicles. With this introduction, and assuming that we have mastered previous book

*Automobile electronics & 4-stroke engines*, we will certainly be able to deal with the problems of diagnosing faults and eliminating them.

So, this program in the main menu offers the choice of scanning individual modules of vehicle's electronic management. Selecting by mouse click, in this case the engine, we get detailed information about the engine



module (on the above sketch we have selected accessory module or *Central Convenience*. In common practice, we usually go first to read the DTCs by clicking on this option. If the program has installed DTCs definitions, it will display them along with the DTC number. If definitions are not installed, we will have to search for them in the *Workshop Manual* or in databases programs. The third option is the Internet. In this last case we should look for DTC definition for particular car make, if it is not

a generic code (P0...) whose definition is valid for all types of vehicles. Factory codes can have the same number for multiple types of vehicles, but the definition is different. Presented codes on photo can be confusing because each code is displayed by one number and than by other in brackets. The first number is the internal manufacturer's or VAG's number. The second is also manufacturer's number as begins with the P1... but is harmonized

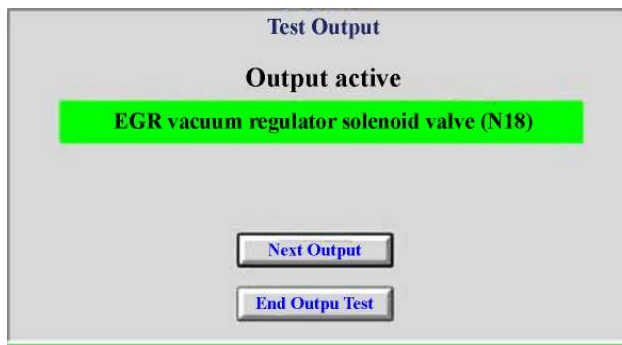

with OBD II standard codes identification. Thus, it is a same DTC marked in two different ways.

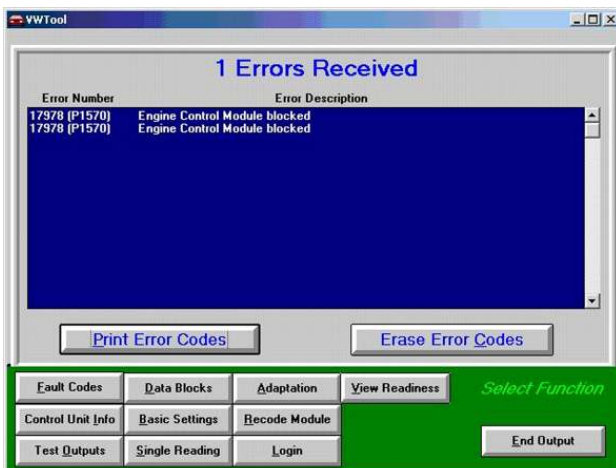

Very practical option is the actuator test. Selecting this option program will give command to the module of the system which we are scanning to drive the actuators. In the sketch we have shown the process of testing the EGR valve. By clicking on the *Next Output* we proceed with the next actuator test. This option can test the solenoid valves, throttle idlemotor, ABS actuators, open

and close the sunroof, electric windows, etc.

Let's go back one more time to the ports synchronization. When we installed this modified interface that covers OBD I and OBD II diagnostic system, we had connection with a computer via a USB port. However, how we can see on the first photo of the interface coated with transparent insulator, KL interfaces have only 9-pin connector for connection to the serial port on the computer or communications port (COM1). Therefore, in the program provided for diagnostics with KL interface, we are offered by default (COM 1) as communication port. Thus, by plugging in the interface with 9-pin connector to the serial port, we only have to check the port settings in the program. If a COM 1 port is already highlighted by default, communication synchronization is solved.

Beside a number of programs for the KL diagnostics which are designed to work on certain brands of cars, it is worth mentioning a very complex program for the diagnostics of all European cars, which beside the engine also covers ABS, SRS, and resets service interval on the most listed car models. This program is known as *Uniscan*, *Euroscan* or *Visa 1.83*. The only disadvantage of this program and interface is that it can not be used with newer computers. However, it is not surprising considering that this is a relatively old diagnostic configuration designed

for installation on computers of that time, as on *Windows* not newer than *Windows 98*. In addition to the older *Windows* such as *Win 95* and *Win 98*, a computer has to have installed the *DOS* program through which this diagnostic works. Problem does not lie only in *Windows* and *DOS*, but in the computer too. This interface is connected to the computer via two 9-pin serial ports which can be found only on older PCs (486 and Pentium 1) and even more rare on older types of laptops. Therefore, if we have this very useful diagnostic tool with which we can do a lot of work, from diagnosis to testing actuators on hundreds car models of European production until the year 2000, it is necessary to obtain an older computer just for this purpose. However, even an extra computer won't be a great expense, because if we find today such a computer its price will be a bargain, which is another reason for having this diagnostic tool. So, we need an older computer with *Windows 95* or *Win 98* with installed *DOS* which is usually installed on such computers by default. In addition, such a computer must have two serial ports, which are marked in *Device Manager* as Communications Ports (COM 1 and COM 2).

On the following photos just some functions of this diagnostic program are shown indicating its broad application. In the first menu we choose car manufacturer. The following indicates the vehicle

model and engine type. After selecting a brand and type of car, we have presented model of ECU in-

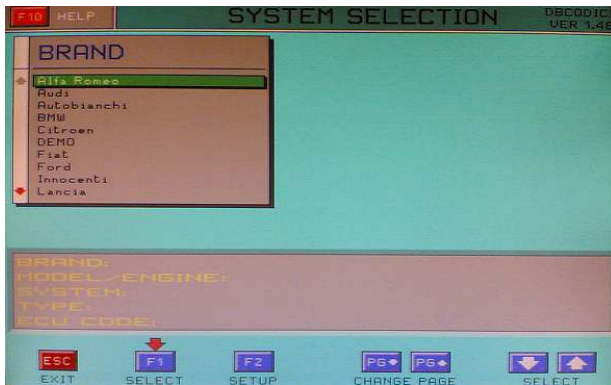

stalled in the vehicle and its position in the vehicle, as well as location of diagnostic connector. Fi-



nally, we have to confirm selected vehicle.

Unlike other diagnostic programs and interfaces, *Uniscan* is



very slow and sometimes gives the impression that program does not work. But with a little patience, this ancient program, by today's terms, will do very well determined functions on its pensioner's mode.

After establishing communication with the engine module, menu with diagnostics options is offered: accessing DTCs codes, parameters, actuators testing, information, ECU program identification and exit. Let's choose the option for testing engine's actuators. This option gives us the opportunity to test: injectors,

EVAP valve and engine idling electric motor. These options will save us a good deal of time that would be otherwise spent to verify the values by ohm or volt meter. When checking injectors, the program will give the command to the engine module to activate each injector and

thus verify its correctness and power supply. But there will be still some work left for us if we have a problem with the injectors.

Namely, this test will not determine the insufficient flow of fuel through the injector, which may be reduced due to accumulation of carbon deposits on the injectors. Therefore, if test determines that injectors are properly functioning and we still suspect the improper fuel dosage, it will be



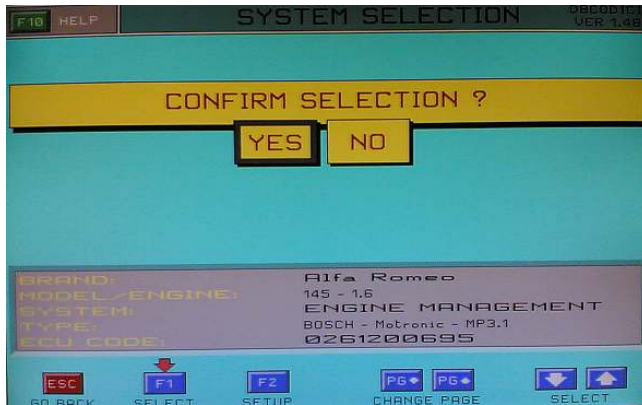

necessary to clean the injectors. However, in case of one injector malfunctioning, this test will be very useful, indicating exactly in which injector problem lies.

work and knowledge. We see how the diagnostic tools are of invaluable help, but only in terms of pointing to the area of existing problems, when we usually have to

knowing that this valve is sometimes quite inaccessible for physical inspection. And in this case will be some work left for us if we have problem with EVAP system. But knowing that solenoid valve is in order, we can focus on hoses leakage and the fuel tank cap. Again we are back to

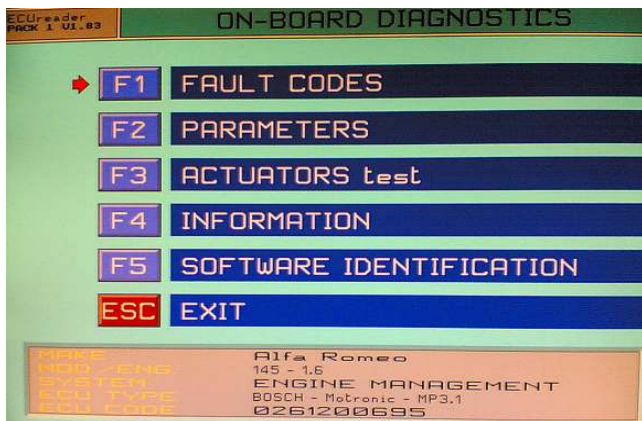

Fast testing of EVAP valve will also save us a great deal of time

this step-motor may be functioning correctly, but we still doubt in its

use all our knowledge and quite some time of physical work to solve the existing problem.

When testing the engine idle speed controller, the engine module will give command to turn the electric motor several times and thus determining its correctness or incorrectness. As in other cases,

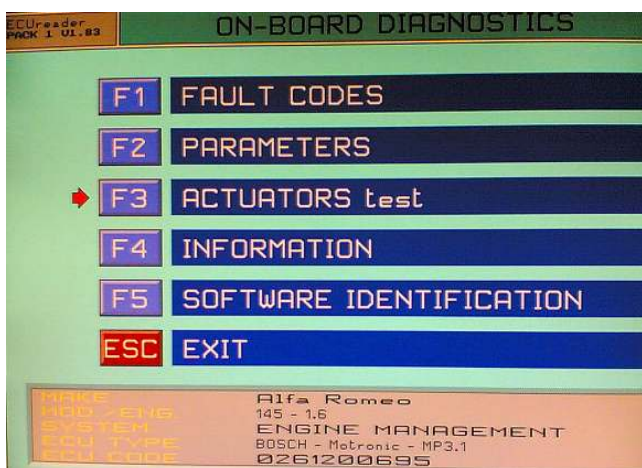

proper functioning. Knowing how the air enters into the engine through the separate channel or passage regulated by step-motor, we can suspect a build up of dirt in the channel and on the valve, as well as on the throttle butterfly which therefore does not close completely and disturbs the proper air proportions entry.



to the battery. The original diagnostics cable will have a connector with three terminals and specially derived red alligator clip for connection with the battery positive terminal or any other positive terminal on the engine or car body.

At the end of this KL diagnosis chapter, here are a few examples and schematic presentation of diagnostic connectors with marked power supply and K and L-lines.

The first sketch of the Alfa Romeo vehicle has labelled connectors: C terminal for K-line, A terminal for L-line, B terminal for ground and terminal B+ 12V power supply which does not exist on the connector. As already mentioned, the power supply for interface

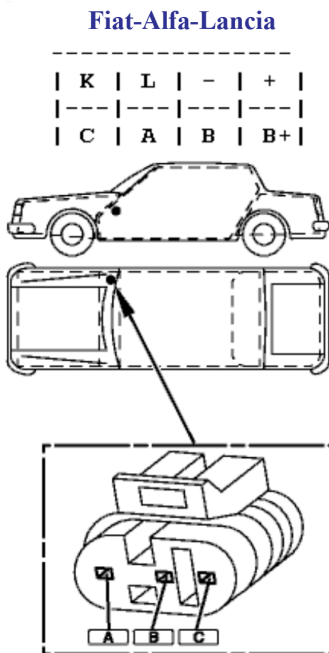

can be obtained directly from battery. So, the Fiat-Alfa-Lancia cars have only three terminals while the power supply connects directly

**BMW**

K	L	-	+
17	15	19	14
20	15	19	14

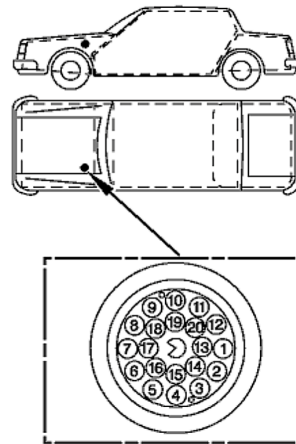

**Mercedes (16 pin)**

	K	L	-	+
KE/DM	3	-	1	16
EDS/LED	4	-	1	16
ASD/				
AMATIC	5	-	1	16
AB	6	-	1	16
KLA/TRAU/				
URB	7	-	1	16
EZL/HFM/				
PMS	8	-	1	16
ADS/URB	9	-	1	16
RV	10	-	1	16
EDW	11	-	1	16
IFZ	12	-	1	16
EAC	13	-	1	16
EFB/LLR/				
MAS/TPM	14	-	1	16

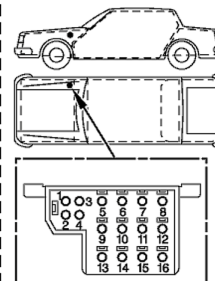

### Citroen

K	L	-	+
2	1	GND	B+

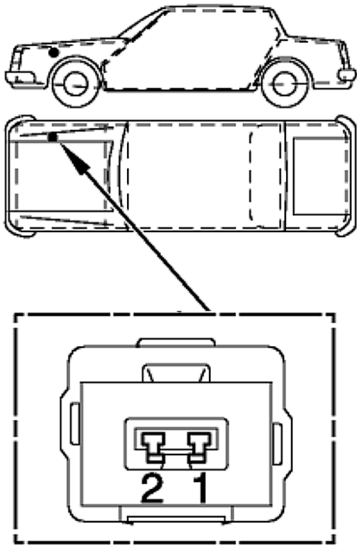

### Peugeot

K	L	-	+
2	1	GND	B+

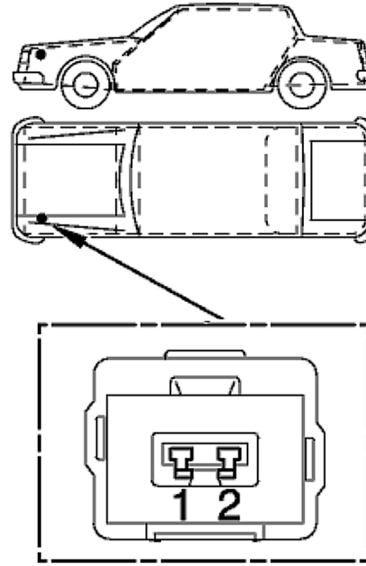

### Ford

K	L	-	+
3	2	GND	B+

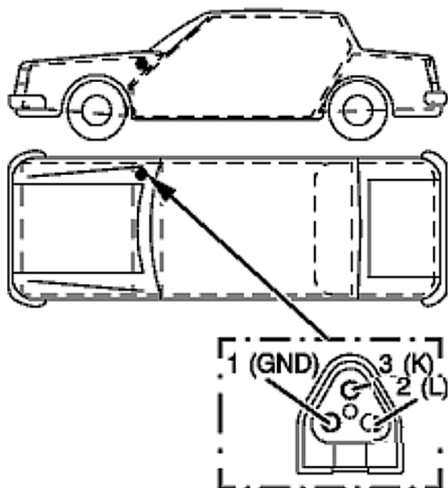

### Renault

K	L	-	+
11	10	2	6

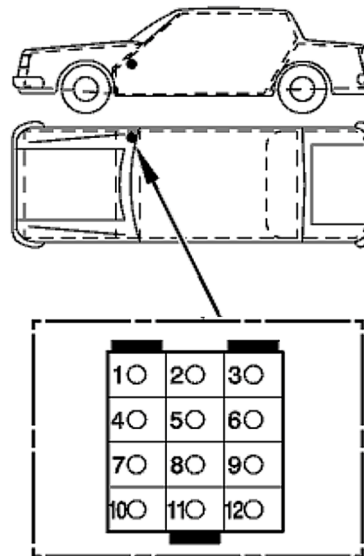

## ***OBD II***

Through the previous text we have seen how difficult is, or rather complicated, to be able to deal with all types of cars and thereby maintain a high quality of diagnosing failures. Dozens of protocols, various terminals, scanners, software and other literature, is essential for such an operation. Not to mention the amount of knowledge and experience.

Such a complex diagnostics system was most suited for car manufacturers. Due to lack of hardware and software, or how we say, diagnostic devices, programs and literature, the authorized services have had a monopoly in terms of maintaining and repairing cars. The law that was put into effect in America in 1996<sup>th</sup> related to ecology forced the manufacturers to standardize protocols and diagnostic connectors. By standardizing the access to data from the ECU, almost all small repair shops were able to access data with relatively inexpensive scanners. Easy access to engine module enabled quickly diagnose and fault repair. We would say in the jargon, where is the catch? Malfunction of any electronic management element will result in increased emissions of harmful gases. Knowing that in most cases we can continue to ride and when *Check Engine* light illuminates, we can imagine how much time will elapse until owner of the vehicle visits authorized service and then waits for another

date of appointment, polluting meanwhile. This was the reason to come up with the law to standardize connectors and protocols in order to enable any repair shop to deal with problems on engine electronics management.

Thus, in 1996<sup>th</sup> a standardized OBD II diagnostic system went from USA. The standardized 16-pin connector had to be incorporated into all types of passenger cars and light trucks. The terminals on the connectors were also standardized. The first step has already been made by the interfaces having only one type of connector for all types of cars, where all terminals were connected in the same order as follows: First terminal is reserved for factory line data availability which are not related to ecology, and for this reason should not be available to everyone. On the terminal two, we shall connect with the interface that has

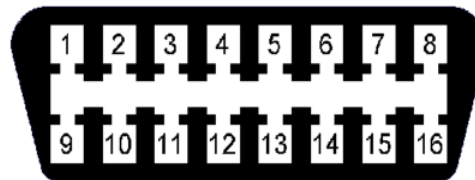

- |                          |                           |
|--------------------------|---------------------------|
| 1 - Empty                | 9 - Empty                 |
| 2 - J1850 bus            | 10 - J1850 bus            |
| 3 - Empty                | 11 - Empty                |
| 4 - Ground chassis       | 12 - Empty                |
| 5 - Ground signal        | 13 - Ground signal        |
| 6 - CAN High             | 14 - CAN Low              |
| 7 - ISO 9141-2<br>K-Line | 15 - ISO 9141-2<br>L-Line |
| 8 - Empty                | 16 - Bat. 12V             |

access to module data with the J1850 bus protocol. The third terminal is empty, and reserved for manufacturers as well as the first terminal. The fourth terminal is ground for interface power supply and the fifth terminal is minus pole for signal transfer. The sixth terminal has access to high CAN data protocol and the seventh terminal to ISO9141-2 K-line. Terminals eight and ninth have the same purpose as terminals 1 and 3. Through the 10<sup>th</sup> terminals we have access to the J1850 data bus protocol, while the terminals 11 and 12 are again free for the vehicle manufacturer. On the terminal 13 we will find again minus pole for signal transfer and at terminal 14 CAN Low. Terminal 15 allows us to access data by the protocol ISO9141-2-L line. That is, terminals 15 and 7 we use to connect with the K and L lines, as previously explained. Finally, the terminal 16 is the 12V power supply for interface.

Even with standardized terminals, there is still a problem with protocols. Namely, after the introduction of OBD-II diagnostic system, the market was supplied with various scanners at acceptable prices. Labels on them marked the protocols through which they communicated with the engine ECM or ECU. For example, if we have obtained the interface with VPW protocol that has a standard connection: 2 Data, 5 Ground and 16 Power, we could not establish communication with the engine mod-

ule which has worked over the ISO and KWP protocol that has the flow of data through terminals 7 or in combination with a terminal 15 (K and L lines) and power supply via 16<sup>th</sup> terminal. So, these two protocols have only in common *Ground* and *Power*, while access to data is on different terminals. Thus, initially it was necessary to know which protocol has to be used for particular vehicle and then use the scanner with the appropriate protocol. Here are some protocols for certain vehicles: Alfa Romeo, BMW, Honda, Jaguar, Toyota, VW ... will work through the ISO protocol. But VW made for the American market, will work through the PWM protocol as well as some Volvo cars made for the Swedish market. Ford Fiesta for the Italian market will work through the PWM protocol and the *Ford Mondeo* for the Austrian market through the VPW protocol. As we see, quite colourful. Such, shall we say, confusing situation with protocols lasted until 2008<sup>th</sup> when new and fast standardized CAN bus protocol started to be used on all types of vehicles.

Protocols for particular vehicles can be found in workshop manuals, but also can be recognized by existing terminals on connector. For example, VPW protocol can be identified by protocol defined contacts terminals embedded in connector, while others will be empty. Certainly, we should not be confused if some other contact ter-



minal is embedded too, providing access to other data. In other words, if we do not know the protocol by which we can communicate with the module, we can recognize it by active diagnostic terminals on the connector.

Until now we mentioned terminals connections for three existing protocols and here are terminal connection lines for other two. PWM protocol has a data access via terminals 2 and 10 and *Ground* and power supply terminals are the same as for other protocols, 4 and 16. CAN protocol will use terminals 6 and 14 to access data, 5 and 16 for the interface power supply.

As we can see, neither the OBD II diagnostic system is quite that simple as the opinion prevails among the car service personnel. To overcome this obviously confusing situation about protocols, which are usually less well-known in the circle of vehicles servicing personnel, diagnostic equipment manufacturers have begun producing Multi-protocol scanners. Such scanners are connected to the all protocol terminals on connector and have an electronic circuit which detects the vehicle's protocol. By connecting such an interface to the vehicle, an electronic circuit in the interface connects all protocols by order. At the moment when interface establishes communication with the module, the protocol is defined and communication between module and program is established.

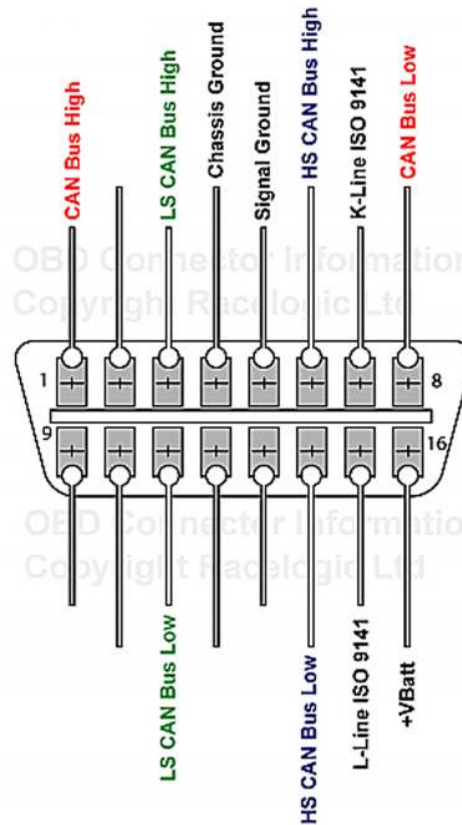

By establishing connection through the one of protocols, we will be able to read data only from the engine module, and all those data that go through it. For obtaining data from other modules, we will have to use an interface and program for the particular vehicle which has connected data terminals for accessing other modules. So, if we want to test the ABS, or SRS, we will require such a scanner and the reasons we have already explained. On presented drawing is clearly visible where in addition to the standard terminals are others terminals connected with different modules. Certainly, today we shall meet more complex diagnostic devices with terminals



on connector, or protocols, to reach data from number of modules beside the ECU, however, the cost of such devices is very high, and again, none of these devices cover all vehicles and all the modules in them. In addition, updating programs for such scanners, usually over the Internet, cost extra.

Next to the protocol name, we noticed the mark *Bus*. Let's explain its meaning. The word bus in the English language means auto bus or coach. Okay, but what it has to do with the protocol? Going back a bit to translate programs and other literature, we note that the English phrases used in the computer world have not any similarity with a literal translation. Such an example, we had with the term *Freeze Frame*. Thus, the term bus is a picturesque term applied to data transferred by the bundle of wires in the electronic management, compared with the full bus speeding on highway. Simply, the *Bus* is the wire line between electronic elements through which address (required information) of recipient is sent, and toward whom required information will be sent.

CAN bus protocol replaces all previous protocols. In standard option of OBD II connector we replaced the CAN protocol on two terminals: on 6 *CAN High* and *CAN Low* on 14. *High Speed CAN* transmits data rate expressed in *Baud rates* from 40Kbit/sec to 1 Mbit/sec. *Low Speed CAN* transfers data at *Baud rates* from 40 Kbit/sec to 125 Kbit/sec. *Baud rate*

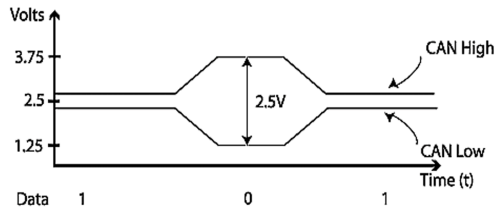

is the mark for pulse per second, or frequency.

How the *CAN Bus* communicates? This protocol uses two wires. One is called a *CAN High* and other *CAN Low*. When the *CAN Bus* is at *Sleep Mode*, and there is no information flow, both wires are powered by 2.5V. During data transmission, the *CAN High* voltage line increases to 3.75V, and *CAN Low* line voltage falls to 1.25V. At this moment difference of 2.5V is generated between the lines, which is in the same time the signal. Such data transfer is not subject to possible environment voltage interference, and therefore no wires protective net coat is needed. It is not uncommon for the sensors and other electronic elements that we see sometimes wrapped with confusing net shield whose only one side is connected to connector while the other side is free. Such wrapper is called the *Shield* which absorbs the external voltage signals and annuls them by connecting it to the ground through the connector.

The OBD II diagnostic system we will also meet as: EOBD, JOBD and ADR. These are versions of OBD II acronyms that indicate areas where applicable as: *European On Board Diagnostics*, *Japanese On Board Diagnostics* and *Austra-*

## CAN Bus Locations

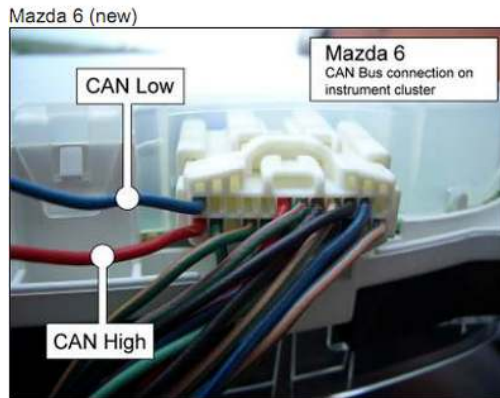

lian OBD Standard.

Just like with KL diagnostics, and here we can play with the *Pin-out Box* if we have appropriate programs. For identification of the CAN bus wires that we need, we can always look for sketches or photographs on the Internet or in other literature.

And, at the end of this chapter, let's explain the meanings of diagnostic protocols acronyms:

**CAN Controller Area Network**, a free translation, control of data transmission networks.

**ISO International Standards Organization**, International Organization for Standardization.

**PWM Pulse Width Modulation**, modulation of pulse width.

**VPW Variable Pulse Width**, variable pulse width.

**KWP 2000 Keyword protocol**, is one more protocol used by manufacturers of European and Asian cars, but uses the same terminals as ISO 9141-2.

*Using the OBD II software and interface*

In some kind of cheaper version, we will use the *OBD II Multiprotocol* interface. This scanner will allow us to access the data from the engine module on all types of vehicles with built-in OBD II Diagnostic System.

These scanners we will find on the market under the name ELM-327, which is usually hidden behind the names of manufacturers such as Scan Tool and others. Depending of the scanner name, the price will vary. Scanners are available with 9-pin serial connector for older computers and USB or Bluetooth connection between the newer computers and interface. With the interface is usually supplied installation disk with drivers and at least one diagnostic Free-ware program. One of the most common programs, which are supplied with the interface, is the *Scan Tool 113win*. This program does not offer too many options such as Freeze Frame, PID, oscilloscope, etc. but it is very quick and easy to use. Two offered options for readings in this program are generally sufficient to solve a series of problems. The first option offers the readings of the engine sensors parameters, and the second one reads the trouble codes and deletes them, as well as it turns the MIL Off (Malfunction Indicator Lamp) or a lamp which warns us about any malfunctions of the electronic engine management.

Procuring such a scanner, CD has to be inserted into the computer to install the diagnostic pro-

gram, in the same manner as previously described. Connecting interface to the computer, we shall install it as a new hardware using the CD which is already in the computer, again in the same way as we have done it before. In this procedure we also have to take care about the ports synchronisations. If we have obtained interface with 9-pin connector for serial port, we shall make connection with interface through the port COM 1. But if we own a scanner with a USB connection, we shall repeat the procedure of synchronising the ports as in the case already described.

When the program Scan Tool is installed and opened, the menu appears with the options offered.

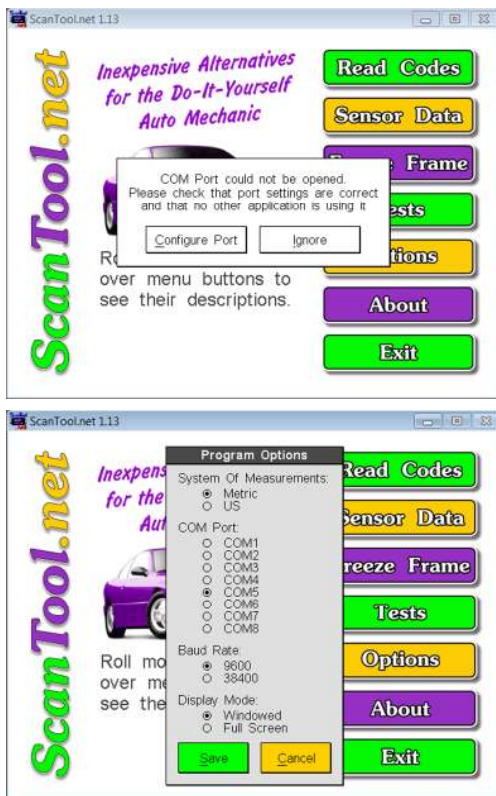

First what we have to do is synchronisation of the communications ports in *Options* in the main menu. As this procedure would not be skipped, when first booting the program the window appears warning us that it is not possible to establish communication with the interface because the port is not defined. If we click on *Configure port*, it automatically opens the *Options*. Unlike the previously described installation, here we have offered eight communication ports. As said before, in the case of connection via the serial port, we choose COM 1, which is already offered by default. If we are connected via the USB port, after installing the interface we will go into *Device Manager* and check if the USB port is listed with numbers from 3 to 8. If so, let's say we choose COM 5 port for communications between the interfaces and program, this port number we will define in the program too, by clicking on the circle in front of the label COM 5. Once we are already in this option, we can modify units by clicking the *Metric* circle. Frequency (baud rates) is not necessary to change because it is generally consistent with the port frequency. But sometimes it can be synchronized with the frequency of selected port in the option *Port Properties* in *Device Manager*. Finally click *Save* and the installation is completed.

The third possibility of connection between the computer and interface is via *Bluetooth*. This con-

figuration is very practical for workshops for two reasons. Using a laptop during the diagnosis is impractical because most often we have to sit in the car with a laptop on our lap or placing it on the passenger seat. In such a cramped space, only one person has access to the results displayed on the monitor. Furthermore, when shifting laptop, there is always a possibility of damaging it, pinning the cables etc. Bluetooth allows us to set up a laptop or PC to a fixed position on the bench where we are comfortably placed and have at hand a paper, pencil and everything else we need. Separate monitor will provide insight into the results displayed on the monitor to other colleagues also, who usually comment presented results in terms of suggesting a diagnosis.

Installed software on the PC will communicate with the vehicle, or interface, via Bluetooth inserted in the computer USB port. Interface for wireless communication has also installed Bluetooth. This interface attaches to the diagnostic connector in the vehicle, and the connection between it and the computer will be established via Bluetooth. Diagnostic procedure with cable connected or Bluetooth interface is identical, except that in the second case we have to match the wireless connection between the computer and interface.

When purchasing wireless inter-

face, along with other popular programs, the *BlueSoleil* Bluetooth software is supplied too, providing data transfer. If this program is not supplied with interface, it can be installed over the Internet as freeware. So, let's go through the installation and synchronisation of this program too.

After installation of the *BlueSoleil* program in the usual way, we shall notice a new icon on the desktop. If the icon does not show up, we can transfer it from *All Programs* in the *Start* menu, as already described. New program opens with double click on the icon

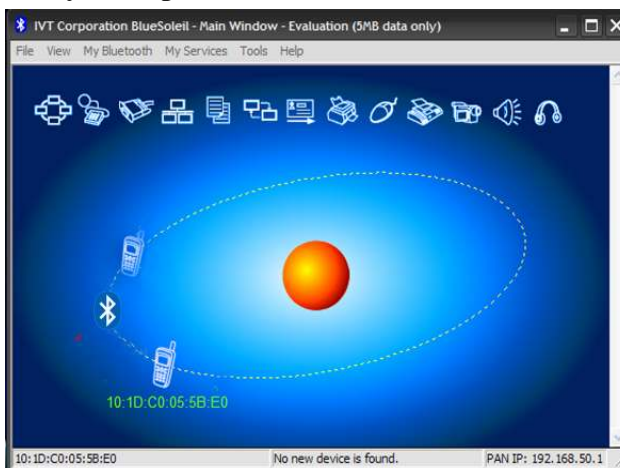

with previously inserted Bluetooth into the USB port. After the Bluetooth self installation, the program is ready for use. If we click twice on the orange ball in the middle of the window, the program will find all Bluetooth devices in the neighbourhood. So, in this presented case a program has found via Bluetooth two cell phones and an unidentified device. This device is our interface. If we have an interface with known manufactur-



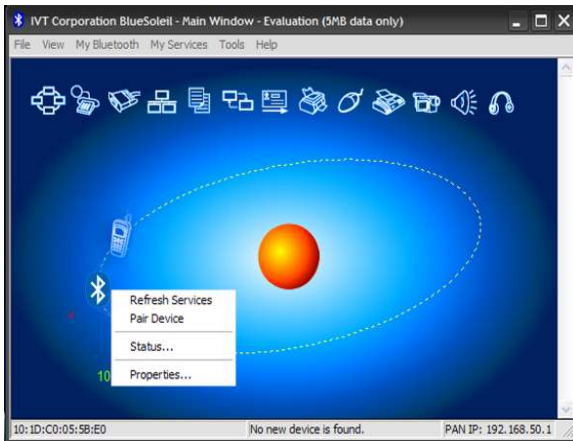

er, instead of this sign, we will see different icon with the name of the company, for example *Scan Tool*.

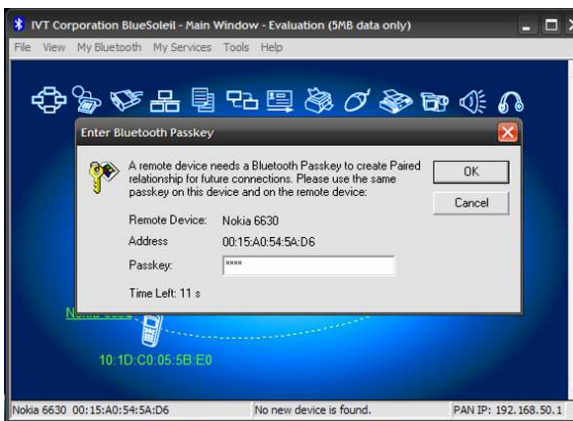

From the found devices select the interface to establish communication. To establish connection with the selected device, we must pair it

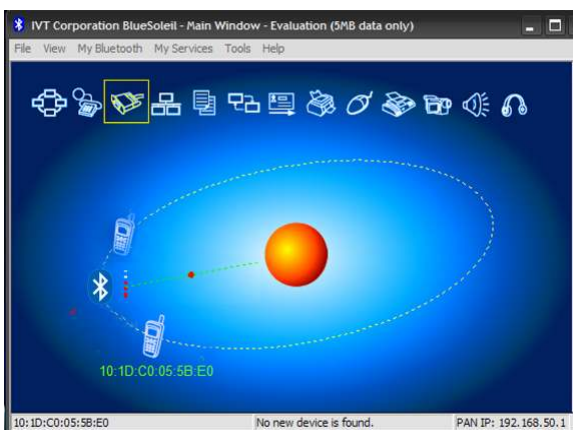

with the program. This function will be achieved by right clicking the mouse button and highlighting our device. In the newly opened menu choose *Pair Device* option, and click on it. After pairing device, new window may appear where we have to enter a password. Password for this free program is: 1234. Enter the password and click **OK**. If the program did not

automatically choose the communication port icon on the top menu, simply double click on this icon.

Once the communication port shows in the yellow square frame, the communication should be established. As soon as the communication is established between the interface and computer, the red dots which connect the selected device and computer will start travelling between the device icon and the orange center.

The number of red dots in the column shows the signal strength. After achieved connection, we can lower the window by clicking on the minus (-) in the upper right corner, and open the diagnostic program. In the case of encountering a problem with the communication between the interface and program, the ports should be checked in the *Device Manager*. In this case, the ports will be marked with Bluetooth instead of USB, as it was the case with USB interface. However, the verification process is identical to the al-

ready described. COM port defined in the diagnostic program, must be listed on the port list in *Device Manager*.

Having passed successfully the installation procedure of the diagnostic program and interface, we can start reading sensor parameters and faults or DTCs (Diagnostic Trouble Codes) in already open *Scan Tool* program, which we took as an example.

In the main menu we can choose between the options *Read Codes* or *Sensor Data*. In practice, we usually have a problem with illuminated MIL which indicates the fault in engine electronics. Therefore, let's first read the codes in order to eliminate the fault. So, we have to click on the *Read Codes*.

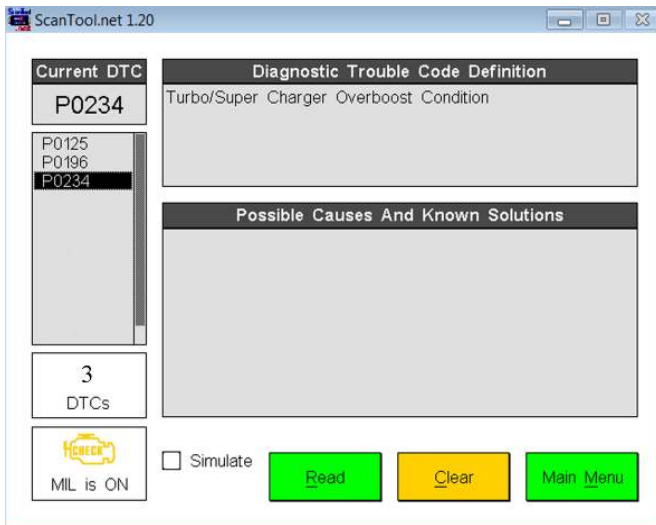

In the presented example we see three DTCs and the MIL is ON. That means, that scanner has pulled out from ECU stored trouble codes and information that *Check Engine* light is ON. By P0xxx codes marks, we can con-

clude that a generic codes are shown, whose definitions are usually stored in the diagnostic program. If we click on the one of displayed codes, its definition will be shown in the window. In this case, we see the definition of the selected code P0234, which says that the *Turbo* or *Supercharger* supplies engine with too high air pressure.

Knowing how the *Turbo* or *Supercharger* works, we will inspect the by-pass valve which directs the exhaust gases to the turbine or partially to exhaust system. One of the most common causes is blocked by-pass valve, what disables redirection of exhaust gases from the engine, and causes too high rotation of the charger and thus the excessive air pressure in

the engine intake manifold. If the by-pass valve is mechanically in order, we can suspect that the problem lies in the control mechanism which operates the valve. Depending of the make of vehicle and type of charger, we will check the vacuum regulator valve connected directly to the charger, or stepper motor controlled by ECU on the newer car models.

If there are more DTCs displayed, it should be considered that some of them may be causal. Namely, if consequence of mentioned displayed code are: high engine cooling and oil temperature, then we can suspect that



these codes are caused by malfunction of the turbine or a *Supercharger*, what usually leads to engine overheating. The DTCs which occurred as a consequence of the real problem will no longer appear after deletion, if the real failure has been corrected. So, when reading trouble codes, it is more than important to think about them and see where the real problem lies among displayed codes. Of course, and again, the theoretical and practical knowledge is essential for proper diagnosis.

If we suspect that there is a malfunction in the engine despite the DTCs shown, write down their numbers and remove them from the ECU by clicking on *Clear*. After a short or long run, we shall re-engage a diagnostic device and repeat the scan.

If we find the same DTCs registered again, we can say with certainty that some malfunctions exist. After elimination of fault, DTCs have to be deleted and MIL lamp turned Off by clicking on *Clear*.

It is not uncommon when reading DTCs, to be in dilemma about the failure due to illogical sequence of displayed codes. In such cases, the *Sensor Data* option can be of great help. Exiting the option *Read Codes* by clicking on *Main Menu* and than on *Sensor Data*, we shall be able to read sensor values. Certainly, in this option we shall need

engine running. If we started the engine by switching ignition Off and ON, there is a possibility that we have lost communication between the vehicle and computer. Port status indicator in the upper part of the program will show us whether the connection is established. The yellow light will be a sign of a broken link, while a green-established. In the case of broken link we shall click on the

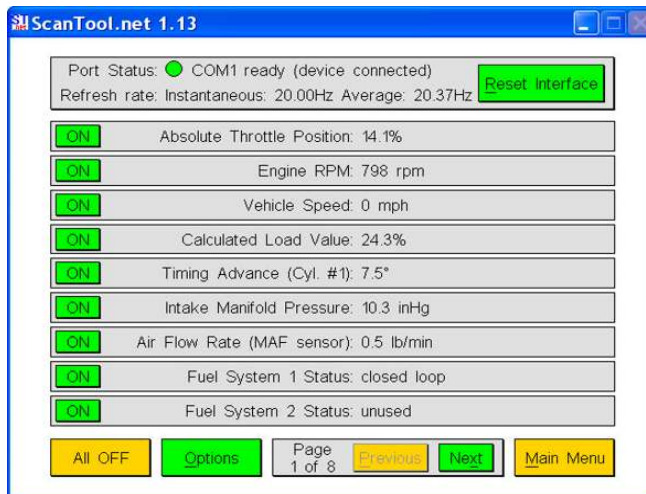

*Interface Reset* in the upper right corner and re-establish the connection.

In this new opened option, we see in the lower part eight pages from which we can read a variety of values or data. But let's start from the first one. The first row shows throttle butterfly opening, which is in this case open 14.1% at 798 revolutions per minute *RPM*. In the third row we can monitor vehicle speed, if testing is done when driving. The fourth row *Calculated Load Value*, tells us about calculated engine power in percent during a certain number of engine

revolutions. In other words, with the shown engine RPM, the available power and torque is 24.3%. ECU performs this calculation by dividing the amount of airflow into the engine with the maximum possible flow. In diesel engines, this calculation is performed by dividing the current torque by maximum torque at a given engine RPM. The fifth row *Timing Advance* shows us the ignition timing in degrees at a given engine RPM. *Intake Manifold Pressure* tells us about the air pressure in the engine inlet manifold. *Air Flow Rate* tells us the mass of intake air into the engine. As we see, the measures in this program are expressed in American or English units. If we select in *Options* Metric readout, measures will be expressed in the metric system of measures. In other words, the air flow will not be lb/min but kg/min; the temperature will be expressed in C (Celsius) instead in F (Fahrenheit).

Here on the first page of reading values, we can do some checking and compare the data without usage of a specific engine data. By increasing the engine RPM, we can follow the timing advance whose value must be proportionately greater in degrees at higher engine revs. A similar situation follows with the air flow. If we doubt whether the MAF sensor works correctly, we will verify the amount of air entering at lower and higher engine RPM. Certainly, at higher engine RPM, the mass of air must be proportion-

ately greater. If there is no significant difference in the mass of air flow, we can suspect that we have defective MAF sensor.

In the row number eight, we find the term *Fuel System 1 Status: Closed Loop*. This phrase can not be explained in a short and understandable sentence. Namely, if we look for assistance in various programs or through the Internet regarding this term, in most cases we shall be confused by various explanations. *Fuel System Status Closed Loop* in a free translation, or explanation, would mean: a closed fuel system circle. However, since this phrase even English born people can not translate or explain in understandable words (see the questions on the forums), it is necessary to understand what the author of this phrase intended to say. Thus, *Fuel System Status Closed Loop* controls the fuel dispensing in the engine via injectors, relying on the lambda probe signals, and other engine sensors parameters. In order that ECU could establish such status, the engine must be running at operating temperature. Opposite to this mode is the *Open Loop Status* which ECU will apply when the engine is cold and Lambda probe is not in operation and the entire system runs on the installed program for such condition. *Open Loop* will also be used while driving under conditions of high engine load, and extreme weather conditions.

In the following example on the new page, we can see a number of

rows where we can read the O2 sensors or lambda probes with different labels. These marks usually give quite a headache when testing because of lack of their meaning. Every diagnostic scanner has a possibility to read several O2 sensors values. To know that readings are related to a particular sensor, they are marked with O2 1, O2 2, O2 3 etc. The word *Bank* has multiple meanings which depend of sentence context. In our case, the closest explanation would be the river bank, left and right. Thus, depend of their positions the probes are labelled as *Bank 1* or *Bank 2*. In an in-line engine, *Bank 1* probe will be positioned next to the engine or before the catalytic converter and the *Bank 2* after catalytic converter. In six cylinder in-line engine with a split exhaust manifold into two groups, the probe before the catalytic converter would be labelled as *O2 sensor 1 Bank 1* for the first three cylinders and *O2 Sensor 2 Bank 1* for the next three cylinders. If such engine has one catalytic converter, the probe behind it would be labelled as *O2 Sensor 1 Bank 2*. In case of two catalyts, probes are

labelled as *O2 Sensor 1 Bank 2* and *O2 Sensor 2 Bank 2*. On in-line engines *Bank 1* is the position of the first engine cylinder. On the engine in *V* formation, *Bank 1* is the side where the first engine cylinder is marked. Number of sensors will depend of number of cylinders and the type of exhaust manifold. If the six-cylinder *V* engine on each side has one exhaust manifold, so-called three in one, then we have one sensor on each manifold labelled as *O2 Sensor 1 Bank 1* and *O2 sensor 1 Bank 2*. Depending of number of catalytic converter on such engine, central one or left and right when two installed, the probe behind the converter will be labelled as *O2 Sensor 1 Bank 2*, or *O2 Sensor 1 Bank 2* and *O2 Sensor 2 Bank 2*. On eight cylinders engine in *V* formation, we will often find two sensors on the exhaust manifold: *O2 sensor 1 Bank 1*, *O2 sensor 2 Bank 1*, *O2 sensor 1 Bank 2* and *O2 sensor 2 Bank 2*. Behind each catalytic converter sensors are labelled as: *O2 sensor 3 Bank 1* and *O2 Sensor 3 Bank 2*.

If we come to the situation that we are not certain which is *Bank 1*, we can always unplug one of the sensors. The program will notice the lack of data from the sensor and immediately determine whether the faulty sensor is on *Bank 1* or *Bank 2*. Due to the misinterpretation of these marks, in practice is often replaced wrong sensor and fault remains uncleared. Of course,

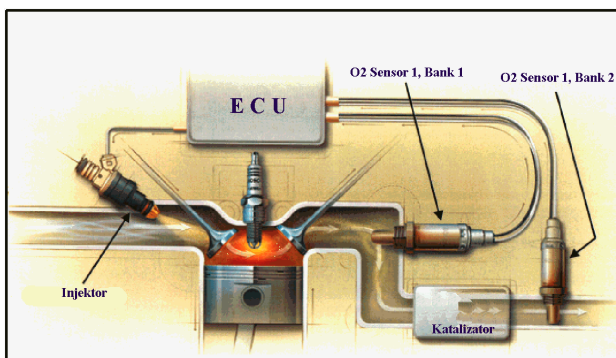

the next step is replacement of the other sensor by the principle of elimination, what considerably and unnecessarily increases the cost of repair.

In most cases, diagnosing a malfunction of the probe is a routine job. But sometimes, it is not. For example, there is a DTC which indicates a defect lambda probe.

Routine work, install a new probe and the problem is solved. The engine is warmed up, DTC is erased and O2 voltage reading is in order. But, the next day the MIL illuminates and the same DTC comes up again. We clear the DTC again and it does not come up until the next day. Where is the problem? When reading the DTC definition, people usually do not pay much attention to the full text. Namely, at first glance we see the O2 sensor code and do not read any further. The definition usually warns us about the short circuit in the sensor, or malfunctioning of sensor heater. Well, and this is solvable by replacing sensor, but obviously sometimes not. Beside the malfunction of the sensor heater, there may be a problem with sensor heater power supply. Thus, the probe heater is in order, but there is no power supply. When engine runs at low temperature, ECU registers faulty sensor heater and turns the MIL on. If we are performing diagnostics test when engine is warmed up and clear the

DTC, it will not appear until we restart the engine when it cools down. Here is another example which points to the caution and requirement of certain checks before a final diagnosis is concluded.

On the shown picture we see readings of the O2 sensor 1 Bank 1 and O2 sensor 1 Bank 2. If the sensors are in order, we shall read the

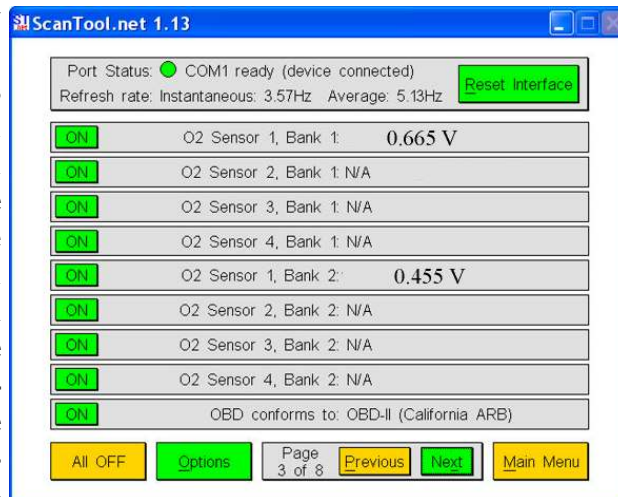

voltage oscillation between 0.2 and 0.8V on the first sensor. Second sensor will have a constant voltage with a value of about 0.45V. Knowing that the front sensor with its variable voltage regulates fuel dispensing through the ECU, such oscillation within mentioned voltage is normal. Having passed through the catalyst CO burns out and gases oxidise. Thus, the exhaust gases value ratio is relatively constant, and so is the voltage at the second probe. In the case of voltage fluctuations on the second probe, we can conclude that the catalytic converter needs replacement. On the following oscilloscope photos, we can see the ideal



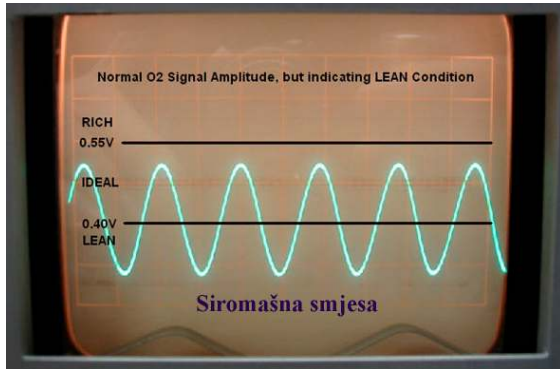
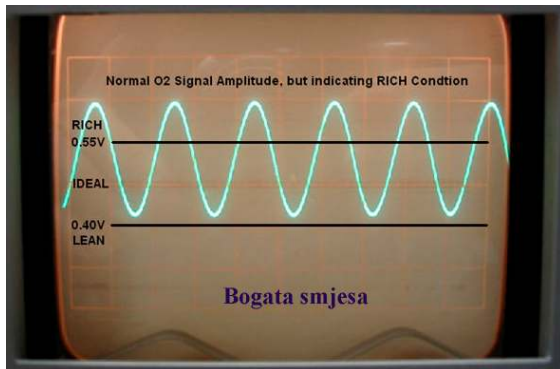
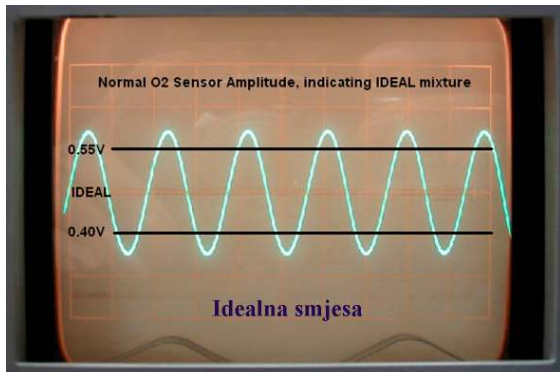

ScanTool.net 1.13

Port Status: ● COM1 ready (device connected) Reset Interface

Refresh rate: Instantaneous: 4.35Hz Average: 6.45Hz

<span style="color: green;">ON</span>	Short Term Fuel Trim (Bank 1): -1.6%
<span style="color: green;">ON</span>	Long Term Fuel Trim (Bank 1): -10.2%
<span style="color: green;">ON</span>	Short Term Fuel Trim (Bank 2): N/A
<span style="color: green;">ON</span>	Long Term Fuel Trim (Bank 2): N/A
<span style="color: green;">ON</span>	Intake Air Temperature: 158° F
<span style="color: green;">ON</span>	Coolant Temperature: 188° F
<span style="color: green;">ON</span>	Fuel Pressure (gauge): N/A
<span style="color: green;">ON</span>	Secondary air status: N/A
<span style="color: green;">ON</span>	Power Take-Off Status: N/A

All OFF Options Page 2 of 8 Previous Next Main Menu

sinusoidal probe voltage, rich mixture voltage and lean mixture voltage.

Constant probe high-voltage due to the rich fuel mixture is not always associated with its malfunction. So, beside a lot of information which we can obtain through these eight program pages, we can check the engine coolant temperature which may be the cause of increased fuel dosage.

Unlike *Scan Tool* which is really satisfactory for the engine and transmission diagnostics, as already said, on the market we can find a serial of commercial and Freeware programs. These free programs are not able to provide any more readings than *Scan Tool* program. But, commercial programs offer some additional options which are related to the engine and transmission only. This refers to the universal OBD II programs. Programs which provide diagnostic options for other vehicle modules are programmed for a particular brand or group of car manufacturers.

One of the commercial programs which provide additional options is the *Scan Master*. This program gives us the opportunity to read PID (Performance Information Data) or in free translation, performance data of individual sensors. In this option, we will be able to read the performance of sensors that are selected on the left side of the

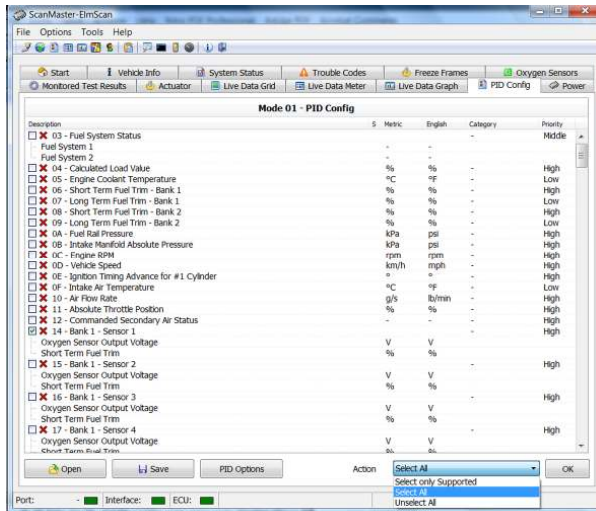

suits the enthusiast, is the: acceleration, torque and power measuring. Selecting *Power* we have opened up the possibility to measure the acceleration and engine power. This program will calculate just how much time has elapsed to reach the speed of 100 km/h, or any other rate that we defined in the *Max speed*.

For engine power and torque measurements (*Dyno test*) will be required to enter

program. Read and compare the performance of sensors selected, is only possible if the program has the original parameters for this vehicle. Therefore, in the lower part of the program we have a choice of performance readings for options which are supported in (Select only Supported) or all the options (Select All).

Let's say that we have MIL On and the code which indicates faulty O2 sensor. Selecting the PID option we can see what data the O2 sensor sends to the ECU. Marking multiple sensors in the PID option, comparing the voltage value or a percentage, we can see how an error affects the other. For example, if we suddenly accelerate, engine RPM will increase and the value of the TPS sensor readings will change as well as the value of the MAP sensor signal due to pressure drop.

Another interesting feature of this program, which would more

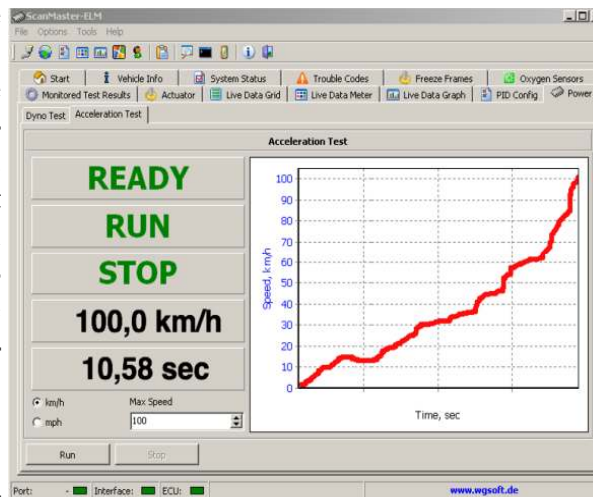

a good deal of data: gross vehicle weight, the weight of the driver and front passenger, baggage, fuel quantity, length and height of the vehicle, wheel size, weather conditions etc. The more information we enter, the more precise measurements are. To make this test the most accurate, it is advisable to make measurements in both directions on the same road track. Knowing that road is never perfectly flat, or that we are going uphill or downhill, the engine power will vary. In addition, however it is



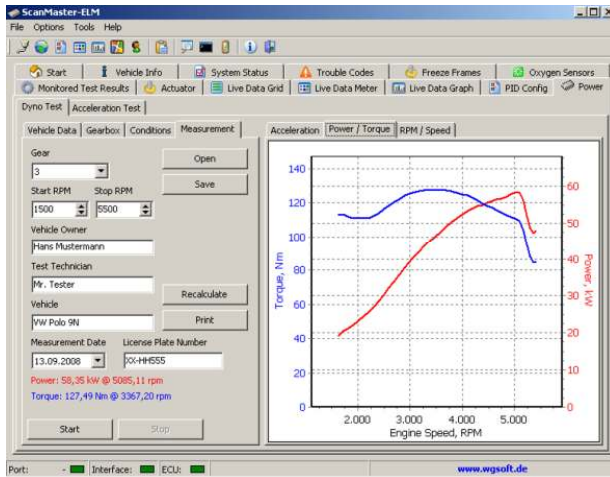

unnoticeable, wind will always blow in our front or back. Finally, calculating the mean value of each measurement, we will get a realistic power. After the test is done, the results can be saved to our computer and printed. In addition to the graph on the printed document, we can see the sequences of

results. Beside the data that we have entered, there are also information of measured engine power (58.35 kW) and power on the wheels (52.69 kW). The difference in power between the engine and driving wheels was lost on the transmission mechanism between the engine and wheels. Maximum power of 58.35 kW is achieved at 5085 rpm. The

maximum torque of 127.49 Nm is achieved at 3367 rpm. Maximum power and torque were measured in third gear.

Let's go back for a moment to those more complex diagnostic devices which can perform more functions on a number of vehicles. Some of the most known devices among mechanics are *Bosh KTS* and *Multi-Diag*. To start with, let's mention that *KTS 570* is offered (Internet) at a price of U.S. \$ 4,510, where some other expenses like postage and... have to be added. We should admit, very serious price. But this is not the end of expenses for such devices. They usually come with the OBD II connector, while the other connectors and cables have to be purchased separately. Furthermore, the program upgrade is charged, if the price does not include one-year free upgrade. Before purchasing, the program content has to be checked to avoid any surprises regarding its testing capabilities in a way: this vehicle or system is supported

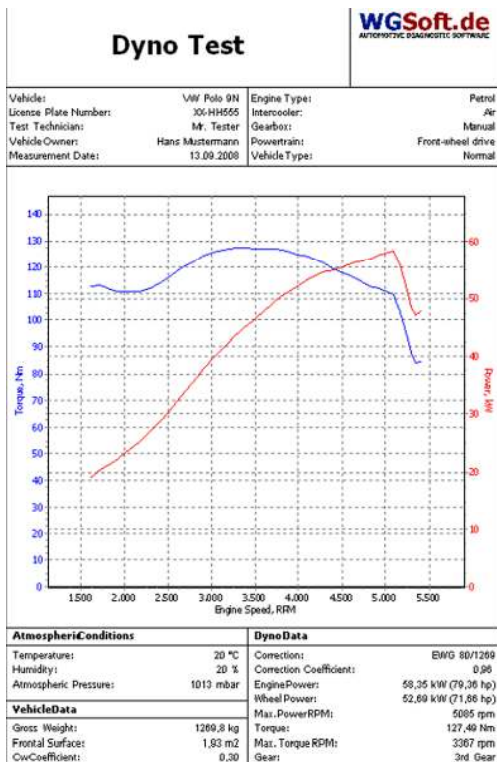

but others are not... Let's say that even we can afford such costly equipment, it will be in most cases useless without adequate knowledge about electronics management and diagnostic testing. Besides having a much more functions than universal ELM 327 device, such expensive scanner does not explain faults any clearer than other devices. Now, we are back again on the trouble codes and the possibility that read DTC does not mean solving the problem by replacing a sensor or actuator. That is to say, without knowledge it simply does not work. In addition, even with these expensive devices *Pinout Box* is often used, and therefore we need to know what are the protocols, *K* and *L* lines and everything else related to the diagnosis. What's more, when we are talking about the functions complexity of such a device, then we can certainly expect much better results from cheaper interface and program, foreseen for a particular type of vehicle. Thus, purchasing one universal OBD II scanner and subsequently buying other devices, financially is far more bearable than buying very expensive equipment, which can disappoint us because we expected quite a lot for such amount of money. Many people do not understand exactly what program

upgrade means. All manufacturers of diagnostic equipment complement their programs from year to year. Knowing that these are not universal scanners, they have to have installed software for particular type of vehicle with diagnostic functions. Because of the programs complexity, manufacturers constantly supplement programs with new types of cars, more functions and expand programs for already listed vehicles. Certainly, such updates someone has to pay. But, that revenue



would not only depend on the program upgrade, the producers launch on the market new devices with improved performances, compatibility, wireless connectivity, etc. So, the only *Bosh* company launched the scanners KTS 340/520/540/650/670, and so on.

The intention of this article is not invalidation of these devices, but only a comparison of their functions with simple universal devices or those foreseen for a particular type of car. Moreover, this was a little warning to those who have believed that the purchase of such expensive devices solve the problem of diagnosing faults on all types of vehicles and their equipment.

An appropriate comparison to the function of such devices is the review of database such as the popular *Autodata*, without which no one decent car workshop can function properly. *Autodata* and *Tolerance Data* have thousands of precious data. However, in comparison with the professional workshop literature (*Workshop Manual*) for particular vehicle, these databases are quite scarce. Therefore, we may conclude that a professional interface and software for a particular type of vehicle will provide far more functions than any expensive universal diagnostics device.

### *Handheld scanners*

In addition to the interfaces and associated programs which work



with the help of the computers, we can find on market a great offer of so-called hand-held scanners. These scanners are very practical for work outside the workshop and quick access to DTCs. So what is the difference between them and



the interfaces that run through the computer? Primarily, computer gives a better program functions visibility on the big screen than it is on, usually very small, handheld scanner display. Furthermore, in addition to the diagnostic program, we have other programs with databases in the computer which we use in diagnosis, and this is basically the biggest advantage.

In any case, when we talk about universal OBD II handheld scanner, it does not give any less information than ELM 327 interface with *Scan Tool* program. Even more, little more expensive handheld scanners provide *Freeze Frame* option, and the PID configuration. Handheld scanners which are designed to diagnose faults on certain types or groups of vehicles can be also very complex in terms of diagnostic programs.

Good example is easy affordable, handheld scanner for VAG group cars with the ability of scanning the vehicles from 1991 onwards. With the scanner and additional small fee we will get the connector adapter for OBD II cable to OBD I (two individual connectors), which is used on cars prior the OBD II system. In addition, it is not uncommon for these scanners to provide readings of ABS and SRS systems and resetting the service intervals. Thus, the seemingly frivolous little braces may well serve the purpose. However, it should be borne in mind that these scanners are designed for quick access of DTCs, while those for use by computer have more complex programs with multiple functions, oscilloscope readings etc.

On the previous page, we can see the photo of a very good handheld multiprotocol middle class scanner *GS 500*, which will along with other information provide the ability to read the *Freeze Frame*. Connecting such a scanner is more than easy. Immediately after connection to the vehicle OBD II connector, the scanner searches for the corresponding protocol. Navigation through the scanner program is simple by using the up and down and Yes-No buttons. This scanner will be equivalent to an ELM 327 interface and *Scan Tool* program with the additional possibility of reading *Freeze Frame*, which a basic *Scan Tool* program does not have. However, if we use ELM 327 interface via computer,



we have the possibility to use different programs which we can purchase or download as a free-ware, while with handheld scanner this is not possible. Thus, it is a matter of choice and needs.

### ***OBD II and new vehicles***

So far we have seen that the OBD II scanners can only access the engine module and provide relatively limited information compared to other options provided by scanner foreseen to scan the certain types of cars. Thus, from a large number of uninformed in the principle of diagnostic tools, we can often hear the question, whether a universal OBD II diagnostic device can read DTCs occurred in the ABS and other systems. In the current text this possibilities were intentionally ignored, in order to avoid misunderstanding in terms of, if it can, why it does not or similar. Thus, the vehicles of the new age are equipped with modern technology related to driving safety, and other comforts of today's cars.

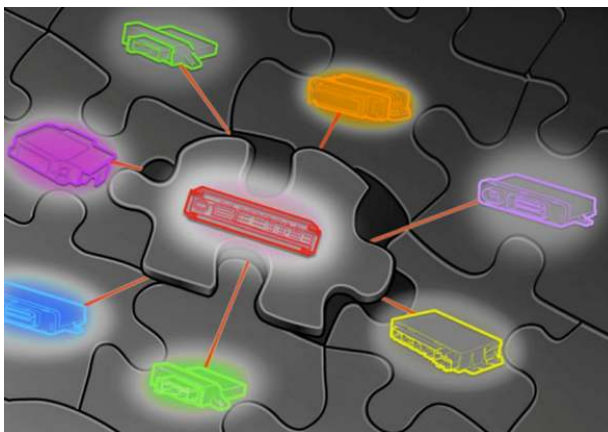

We will mention one of many examples where universal OBD II scanner can read DTCs associated with ABS. A car that has a built in ESC (*Electronic Stability Control*), uses ABS system and engine module to control the vehicle stability. When vehicle has tendency to drift due to excessive speed, slippery road and similar situations, the ESC module will use the ABS to slow down one of the wheels to help stabilizing the vehicle. At the same time, it will automatically reduce the engine power to prevent sudden acceleration which could additionally disturb the vehicle stability. Using a very complex calculation of all available parameters, this ECM will maximally stabilize the direction of the vehicle. As we see, the complex process of vehicle stability control requires an interaction of engine, ABS and ESC modules. In one such integrated circuit of several modules, where the main module is engine control module, all data will be stored in the ECU, or engine computer.

If we know that the OBD II scanner has access to data from the engine module, in this case it will be able to access all data stored in it. In other words, if there is a problem or fault in the ABS system, it will be stored in the form of DTC in the engine module, and will appear in option of *DTC Reading* on any OBD II scanner.

The shown photo, humor-



ous but very clearly, shows the integration of ECMs, where the central computer is the chief of situation, for now still the ECU. If we have this situation in a modern car, all stored codes will be available to us through the ECU regardless of system to which they are related: ABS, ESC's etc.

Vehicle manufacturers are obligated to provide access to trouble codes which are related only to the ecology. These are mainly the generic trouble codes with marks P0xxxx. However, it is very difficult to select the availability of generic and factory codes. Therefore, manufacturers use their codes for which many technicians do not have definitions. But we saw through the previous text, that this obstacle is not insurmountable. In addition, environmental laws are now so rigorous that some kind of malfunction of other systems in the vehicle can affect excessive pollution. Thus, according to the world's regulations, air conditioner malfunction can cause pollution. Insufficient air pressure in tires will contribute to increased fuel consumption. Improper setting of the suspension (where automatically adjusted) will affect the air resistance in terms of turbulence, and also contribute to increased fuel consumption. Automatic adjustment of lights, in case of failure could endanger someone's life, etc. Therefore, more or less, all systems on the car are subject to enabling fast fault recovery, and hence a simple approach to

trouble codes.

Availability of trouble codes should not be a secret for a number of circumstances which can put a vehicle's owner in some inconvenient situation. For the mentioned reason, on some vehicles DTCs are displayed on the instrument panel. For example, even older Jaguar models, say produced 1990th have the button, whose function is defined in the owner's manual, which we can press and read the DTC, or fault in the electronic management of the vehicle. Thus, even then the choice was left to the vehicle's owner, whether to service or repair his car at an authorized service center, or elsewhere. Of course that such company could afford easy access to DTCs relaying on Jaguar's owners decisions to maintain their vehicles nowhere else but in official Jaguar services. Returning to the diagnostic procedure described in the previous article, we are aware that access to DTC's does not mean successfully and simply solving the problem.

Using OBD II scanner on new cars, many will be surprised how much information is available. If we take for example today's cars which uses a modified gearboxes, mainly controlled by the ECM, faults at all actuators on *Automatic, Tiptronic, Dual Clutch* and other types of transmission will be accessible by simple OBD II multi-protocol scanner.

As always, one has to be careful when giving instructions as there is

a need for a warning that such a scanner is not all diagnostic equipment that we need for proper diagnostics, regardless of the expanded capabilities of accessing the information. So, a simple OBD II scanner will be able to draw out all the trouble code from the central ECM on newer vehicles. But, that is all, no further testing will be possible to run without the proper interfaces and programs. However, to an expert, DTC or fault code should be sufficient to cope with a problem or malfunction of the vehicle.

#### *Pending codes P0xxxx \**

When reading the DTCs, we often encounter the trouble codes which are usually marked with an asterisk, PD or *Pending Code*, in free translation error in development. This type of code stored in the module memory will not turn on the MIL. What is it? There are number of situations which can cause the sensor or actuator failure for a short time. Such failure can last for a second or two, but enough to be registered by module. If the fault is not constant, computer is not sure if problem is real, just some coincidence or kind of causal error. Therefore, the module will register an error, but will not record it as effective until it is repeated and the calculations show the actual defect. Therefore, when we encounter such a code, it should not be ignored, but definitely taken into account as a

cause of possible problem. After recording the code number and eliminating the real fault, we can wipe out the code from module memory and check after a while if it comes up again. If we encounter during the scanning just such a pending code, after writing its number down we can delete it and check if it shows up again after a while.

In case of repetition of the same DTC marked as *Pending code*, the error is probably related to mechanical problems. Suppose that we have such a code associated with MAF or MAP sensor, the cause may be a light damage of one of the vacuum hoses connected to the engine intake manifold. When the code is associated with turbine, such failure may be related to the defective (sticking) bypass valve mechanics which redirects exhaust gases. Partially defective fuel cap may indicate a malfunction of the *Purge Valve* (valve for removing gases from the fuel tank).

If we are not sure what to do with a *Pending code*, and assuming that the engine is running smoothly, it is advisable to leave it in the ECU memory. If the error does not show up again after about forty times that engine is restarted, and after running at the operating temperature, the module will delete it from memory. If the error is repeated, the module will register the problem as an existing DTC, remove the asterisk and turn the MIL on.

### *The most common causes of trouble codes*

In this section we shall have some examples of trouble codes where the problem does not lie in the failure of sensors or actuators. As said before, the error stored in the engine computer only directs us to the particular sensor or actuator, and never suggests its replacement as solution for solving problem. Therefore, before deciding to replace a particular part, it is necessary to make a series of checks. For this purpose, the biggest benefit is a universal multimeter which can measure: voltage, resistance... Voltmeter will measure the input or output voltage, while the ohmmeter will help us to test coils or O2 sensor heater. In addition to tests which we can do ourselves, it is advisable to use professional factory books, if available, which are foreseen to help repairers of certain types of cars with various sketches and data.



Such a literature leads to more possible problems associated with individual trouble code numbers.

Described examples do not solve problems related to the trouble codes, but can definitely be helpful in diagnosing procedure.

### *O2 sensor DTC problems*

This example is related to the reading of a constant low or high voltage on the lambda probe, as well as very slow or no voltage oscillations.

Lambda probe reads presence of oxygen in the exhaust gases, and generates a voltage signal proportional to the amount of oxygen. The voltage signal can vary from approximately 0.1 to 0.9V. Low voltage indicates the lean mixture and the high voltage rich mixture. When the engine is at operating temperature (*Closed Loop*) the ECU uses the voltage signal to balance the mixture. Faulty sensor will disable the *Closed Loop*, and the result will be increased fuel consumption.

Constant low voltage signals can cause the occurrence of DTC, which indicates a malfunction of the probe. However, the cause of the low signal value may lie in damaged vacuum hoses connected to the engine intake manifold. The entry of additional volume of air will pauperize the mixture and automatically increase the amount of oxygen in the ex-

haust gases. The same case we shall have if there is a damaged gasket on intake manifold, as well as on exhaust manifold. The misfire of one or more cylinders or a burnt exhaust valve can also be cause of excessive oxygen in the exhaust gases. In both last cases, the unburned gases will increase the amount of oxygen in the exhaust gases.

Test of the O2 sensor has to be done by reading the voltage oscillation when suddenly fuel-air mixture is changed. Apart from reading voltage value with voltmeter, this option is provided in every OBD II program. When the engine is at operating temperature, disconnect a vacuum hose from the engine inlet manifold. The value of voltage at the test must fall sharply and quickly. Small, slow or no change in voltage certainly indicates a malfunction of the probe.

If, in addition to the O2 sensor, trouble codes are also related to the MAP sensor and the occasional misfire, problem usually lies in a serious vacuum leak from the intake manifold. Vacuum leakage which is often the cause of mentioned problems usually is present



only during the engine operation at idle.

Checking the vacuum leaks can



sometimes give a real headache, especially if there is a small leak. In the number of cases, vacuum leak is not visible or hearable. Apart from the described possibilities,

the vacuum leak can be expected on the worn fuel injector seals, which are usually inaccessible for inspection. In certain cases we can use *WD 40* spray for finding smaller leaks. Spraying vacuum connec-

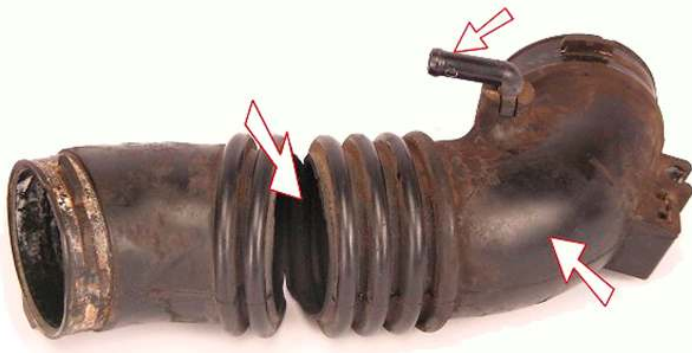



tions when engine is running, we can hear and see the entry of fluid into the intake manifold. Moreover, when we encounter a vacuum leak with spray, the engine RPM will change for a moment. In the photographs we see several examples related to this problem. It is not necessary to mention that there are various instruments to check the vacuum leaks. However, in most cases, we have to cope with minimal equipment which we have on disposal.

### ***MAP sensor DTC problems***

MAP sensor, depending of the type (see *Automobile electronics & 4-stroke engines*), changes the output voltage as the vacuum changes in the engine inlet manifold, and it is the one of the parameters that ECU uses to determine the moment of ignition and dosing fuel. Malfunction of this sensor will af-

fect the engine performance and may be manifested by slow acceleration, lack of power etc.

As it was the case with the O<sub>2</sub> sensor, here we can also look for problem in a vacuum leaks. If the engine is equipped with TPS sensor, we can compare the values of voltage oscillation on both sensors, which should be proportional. Regardless, whether on one of these sensors value rises or falls during acceleration, the value must be proportional on

both sensors. Suppose, that by opening the throttle at the engine inlet manifold TPS sensor indicates voltage deviation by plus or minus, the same situation we should meet at MAP sensor. Vacuum is the strongest when engine is running at minimum RPM (idle). By opening the throttle vacuum is reduced, and the MAP sensor registers it by stronger or weaker voltage signal. If there is not TPS sensor installed, we are measuring MAP sensor output voltage at different engine RPM. If after these checks, there are doubts about the accuracy of the sensor, we should check the power supply on the connector and perform the identical test previously described. Disconnect the vacuum hose from the intake manifold and monitor the changes of output voltage values. If the power supply is correct and we do not notice the change of sensor output voltage at



this test, we can conclude that the sensor is defective.

If we use the OBD II program for such test and choose the option *Sensor data* we can read the pressure values at different engine speeds (RPM). The value of pressure is shown in row *Intake Manifold Pressure*.

On the shown graph we see the reaction of the MAP sensor when vacuum oscillates in the engine inlet manifold. By increasing the

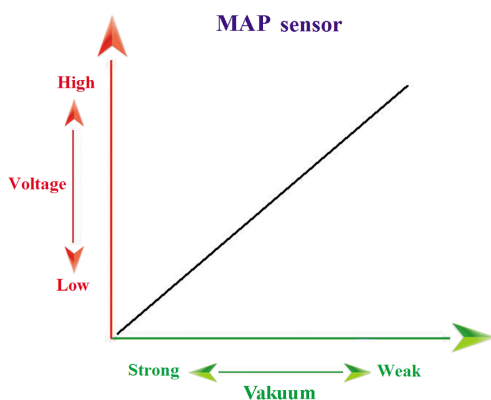

engine speed, or opening the throttle, the vacuum in the engine inlet manifold drops and sensor output voltage increases.

### ***TPS sensor DTC problems***

Among other parameters from the TPS sensor that ECU uses in the calculations of the air-fuel ratio and ignition timing, one of the most obvious problems related to this sensor is hesitation during the rapid acceleration. Wrong or undue signal in the form of changes in output voltage from the sensor may be the cause of this problem and others related to engine per-

formance and fuel consumption.

Checks and measurements of this sensor can be also performed with the voltmeter (depending of the type of sensor). Knowing that these sensors usually work as sliding resistors, it will not be difficult to conclude that the output voltage is proportionally falling when opening or closing the throttle. Of course, it is necessary to check the sensor power supply on positive terminal of the sensor connector. As these sensors are mostly mechanical sliding resistors, the problem is mainly associated with oxidation of the sliding elements or worn bushes causing free-play in the sensor and poor contact.

It often happens that measuring of output voltage is correct, but after running car for several kilometres MILL turns back on with the same DTC. Therefore, when measuring the output voltage from the sensor, use a plastic screwdriver handle and gently tap on the sensor. If there is a poor contact on electrical sliders inside the sensor, we will not have continuous but interrupted output voltage. If this is the case, we can conclude that sensor is defective. Such a sensor can be replaced, but those more experienced can try to dismantle the sensor, clean the contacts and test it again. Certainly, such task can be performed on older vehicles models, while newer cars have mostly sealed elements which can not be repaired.

On new types of cars, TPS sensor is automatically calibrated by the

installed program in the ECU. On older types of cars, it is necessary to calibrate the TPS. Calibration possibilities we shall find only in more complex programs provided for the diagnosis of specific types of vehicles.

In the photographs we see the usual TPS sensor position on the

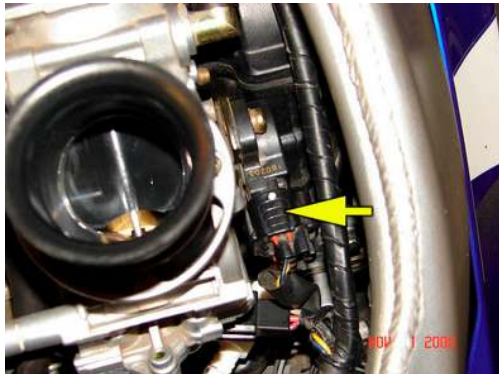

throttle shaft, and disassembled sensor with sliding contacts. Going back to the sensor test, it should be

noted that skilled mechanics will cope with sensor terminals and measurement values. The others will look for specifications in workshop manuals or in data programs.

On the following sketches we see shown examples of connecting and calibrating the TPS sensor in the program for a particular type of vehicle. TPS sensors usually have only three terminals. On the sketch, the positive terminal or sensor power supply, whose value is usually 5V, is highlighted in yellow. The negative terminal or earth is highlighted in black, while

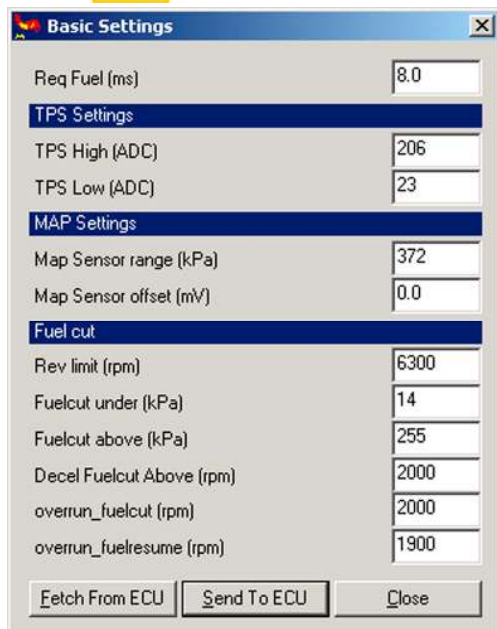
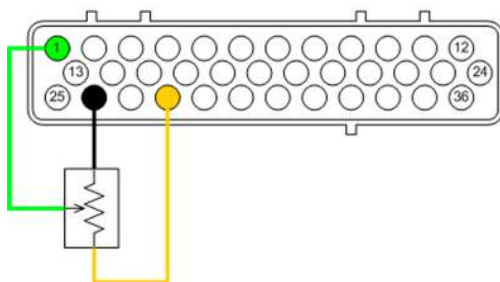

the sensor output terminal whose voltage value varies from 0-5V is highlighted in green.

On the program window we see the option *Basic Settings*. The menu shows the values of the TPS sensor (TPS Settings) in the highest (High) and lowest (Low) throttle opening position, which we obtained by clicking on the *Fetch From ECU*. If the program does not provide automatic values adjustment for particular type of engine, we can enter them manually, previously finding them in workshop manuals or else where. After entering appropriate values and clicking on the *Send to the ECU*, we have completed the sensor calibration.

### CTS sensor DTC problems

Coolant Temperature Sensor can give quite a headache in terms of causal errors. Malfunction of the sensor will affect significantly elevated concentrations of carbon monoxide due to the excessive dosage of fuel. Engine coolant temperature sensor also acts as a resistor. It is usually supplied with voltage of 5V, which drops in the output signal as sensor heats up. This information will be used by ECU to increase the dosage of fuel until engine reaches the operating temperature.

Suppose two situations. Resistor is in a short-circuit, and signal has a constant value of 5V, regardless of engine temperature. The engine will run smoothly until the coolant

warms up, when the mixture becomes too rich, and engine starts to run erratically at idling with significantly increased consumption and tendency to stop running. There is also a quite confusing situation in the ECU processor calculation system. Lambda sensor reads high concentration of carbon monoxide, while the temperature sensor provides a signal that the engine is cold and needs increased fuel dosage. After a certain period of engine running under such conditions, leads to deposition of carbon on the lambda probe, what completely disrupts its reading. It is quite obvious that chemical process in catalytic converter is also disturbed, and control probe will send negative signal accompanied with few more errors related to fuel pressure, etc. So, in this case also, we read several DTCs but problem lies in only one of them. With a good theoretical knowledge, everyone will first consider the validity of the CTS sensors. How to test CTS sensor?

As in previous examples, we will first check the sensor power supply. It is strongly recommended to use the multimeter instead of test lamp which is commonly used in such procedure. Due to possible incorrect connection, the test lamp may cause a short circuit with very undesirable consequences. If we have, when ignition is on, power supply of 5V or other value specified for particular vehicle, we can perform the sensor testing. The sensor can be tested on the engine,

or when taken out.

With the multimeter we shall measure the resistance between two terminals on the sensor, which value, in this case, suppose to be 7000-13000 Ohms when sensor is cold. By heating the sensor, the resistance must be proportionately reduced to 700-1000 ohms when engine reaches the operating temperature. If there is no difference in the resistance, the sensor is faulty.

Why should we test the sensor if DTC shows its obvious failure? Primarily, because reading showed several codes instead of one. Furthermore, the problem does not necessarily lie in the sensors failure. Insufficient coolant volume

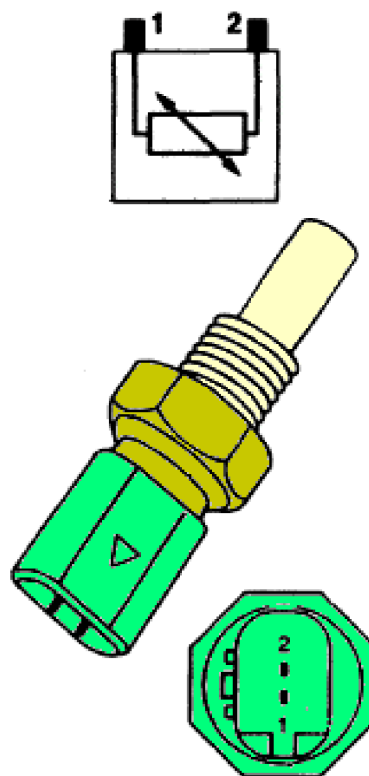

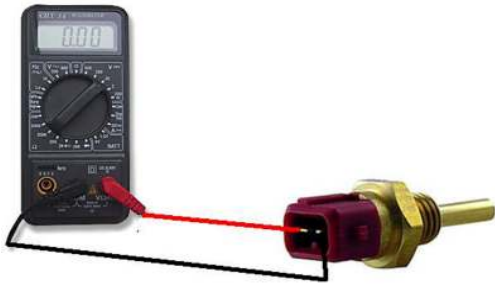

will affect the faulty sensor response. In such cases, the heated coolant will not heat the sensor, but only a formed steam to which the sensor will not react as it would immersed in the liquid. Another problem may lie in the thermostat failure, which does not close the fluid flow completely and thereby preventing the engine to reach the operating temperature. Therefore, if we want to be absolutely sure that we know we are doing and prevent possible unnecessary investment, it is advisable to test the sensor. Presented sketches

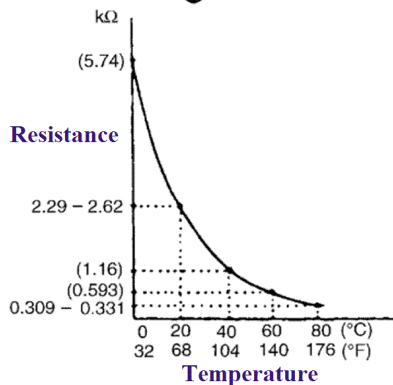
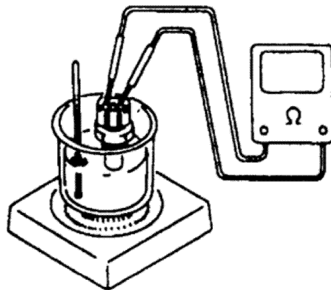

show the CTS sensor test procedure.

The last sketch shows the sensor test when immersed in a heated fluid. On the chart we see how resistance increases when sensor is heated. This is the opposite situation from previous one where the resistance decreases by heating the sensor. In any case, the resistance changes its value by heating the sensor, either by reducing or increasing the resistance value. Just because of such different values, it is very useful to use the literature for particular vehicle, so that we know what we are looking for. Such information is quite helpful if we are performing test by short connecting terminals on the connector. Suppose we have a case of excess fuel as described before. Knowing that resistance is reduced by heating the sensor, we can bridge the two terminals on the sensor connector and see the effect. How? If warming reduces the resistance of the sensor, the value of the sent signal to the ECU, at engine operating temperature, will be 5V. The same values of the signal we shall get by short connecting two terminals. In other words, if the sensor was faulty, leading the full voltage output to the engine computer, we provide information of the engine operating temperature achievement. Taking into account this information, the ECU will reduce the dosage provided for a cold engine and switch on the *Closed Loop*, when it relies on the Lambda probe signals.



### *Misfire DTC problems*

*Misfire* term is usually badly defined and interpreted. The literal translation would be the lack of fire, which is not so bad explanation. However, this term refers to the malfunctioning of one or more cylinders, either due to lack of spark or fuel. When such codes appear, we shall read *Random Misfire* or *Misfire of 2<sup>nd</sup> cylinder*, or some other number. In the first case we have a problem with sudden malfunctioning of several cylinders without any order, or, we would say, randomly. In the second case, malfunctioning refers to the cylinder number 2, or some other numbered cylinder. This means, that the ECU has detected discontinuity of functioning on one or more cylinders defined by numbers.

*Random Misfire* usually occurs due to the bad fuel or some impurities in it. The cause may also be due to failure of the vacuum hoses or worn seals. Disrupted ignition timing and carbonized injectors are also often the cause of these errors. Worn out distributor cap (on engines with distributor) and spark plugs cables covered with dirt and grease can also cause disruption of cylinders without any order.

When a *Misfire* DTC occurs with cylinder number, then we know that we have to focus on that cylinder and look for the cause of firing interruption. To solve such problem, theoretical knowledge and

experience will be of great necessity. Most often, we firstly check the condition of spark plugs. Having in mind how any mechanic is familiar with problems caused by spark plugs, cables and pipes; let's talk about misfiring of cylinders in pairs. Vehicles which have two ignition coils, or one for two cylinders, and the error refers to a pair of cylinders that are connected to the one of them, we can doubt its validity. On vehicles with a separate coil for each cylinder, we can apply the test by exchanging the coils from one cylinder to another, and see if the error will again refer to the same cylinder, or the one on which we set up a coil of doubtful validity. The same test can be applied in the first case too, if we have identical connectors. Such verification will certainly determine, whether we have defective coil, or the problem lies elsewhere.

The second problem usually lies in the injectors. If we suspect the injector, it is recommended to replace it with one from another cylinder. The test is identical to previous one with coils. If an error occurs with the number of cylinder where we installed the injector with dubious validity, we can conclude with certainty that injector is faulty. However, if the error repeats with the same cylinder number as before, the problem lies elsewhere. Certainly, if we swapped coils and injectors between cylinders and found nothing wrong with them, but DTC still exists on the same cylinder, we

should look for the problem in the worn vacuum seals or, furthermore, bad piston rings and valve seals, which will cause accumulation of oil deposits on the spark plugs.

In practice, the occurrence of such DTCs is usually caused by deposit of carbon on the injectors where occasionally proper injection fails. It is not uncommon that mentioned checks are performed, and, in those worse cases, very costly replacements of injector, spark plugs cables and coils are done, without any results. Just for this reason, these tests are recommended. Satisfied with all performed tests which have showed the correctness of all electronic elements and mechanical parts, injectors cleaning is all what is left to be done. Do we have to do this job before or after these tests, it is difficult to say. Those a little more experienced will be lead by vehicles mileage and bring the right decision. Certainly, if we work on the vehicle with mileage of several hundred thousand miles, we shall immediately suspect a carbon deposit on the injectors, while on

those with low mileage we shall first perform described tests.

Injectors contaminated with various sediment, are the most common cause of hesitation during the acceleration and uneven engine idling, including *Misfire*. On the photographs we can see the irregular fuel injection due to deposits of carbon and other materials. Proper injection is shown on comparative photo. So, let's say something about the possibility of cleaning the injectors. The simplest way is pouring special chemical product into the fuel tank, which will pass through the injectors and dissolve the accumulated material. Such a procedure is quite effective, if there is a milder form of deposits. In more serious cases of deposited carbon and other impurities, injectors have to be removed from the intake manifold and cleaned by machine. If we want to save some money, a similar procedure can be done by purchasing a spray, and clean the injectors under the pressure with its content. The photo shows this process with the help of battery which activated the injector solenoid and opened flow.

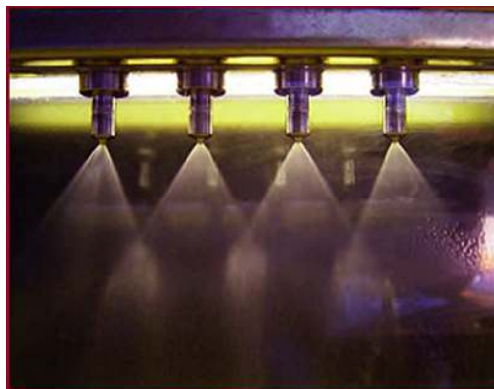



Some sprays offered on the market, allow us to empty its content directly through the throttle, previously removing the air filter. Such sprays will clean the outer surface of injectors, deposits on valves, pistons and cylinder compression area. But if we want a proper injectors cleaning without risk of

failure during the cleaning, they should be connected to the cleaning machine. Using professional equipment to clean injectors, allows us to have the flow of solvent through the injector until we are satisfied with proper fuel injection. During the cleaning, these machines allow us to measure the amount and equalization of the fuel flow through the each injector.

On the next photo we see a typical injectors cleaning machine. Unlike the smaller available machines, this one can clean and test



up to eight injectors at once. In the measuring cups below the injector, we measure the quantity of injected fuel, which ideally should be identical in all eight cups.

### *EGR valve DTC problems*

Problems related to the EGR valve, usually are results of failure on vacuum or electromagnetic actuator due to the accumulated carbon deposit. It is not uncommon to

have blocked passages through which the exhaust gases pass into the engine intake manifold (see how the EGR valve works in the book *Automobile electronics & 4-stroke engines*).

Testing the EGR valve begins with checking the vacuum or solenoid operated valve. If there is a vacuum operated valve, it is necessary to check the vacuum and vacuum regulator which operates the valve. Weak vacuum or no vacuum at all, at the valve, usually is the result of the worn hose or a bad connection. The solenoid valve will be checked by bringing power supply directly to it from the vehicle battery. Such a test would not be effective if we do not take the EGR valve assembly of the engine. In most cases, carbon deposit on the mechanism (valve shaft) is so great that it disables the opening and closing of passages for gas flow, even when the actuators are working. Therefore, in order to properly determine the condition of the EGR unit, it must be removed from the engine, the carbon deposit dissolved and the entire assembly thoroughly cleaned. Only after we have cleaned all dirt from the housing and all mechanical moving parts, we can test the actuator. If there is a vacuum actuator, we can test it by connecting it to any vacuum hose on the intake manifold. The vacuum will lift the diaphragm and the valve must be fully open. After that, we have to test the vacuum regulator which is controlled by the ECU. Knowing how

EGR works and when the valve is opened, such a test will be harder to do when the car rests. However, if we found a defect during the cleaning and testing the unit, further testing, most probably, won't be needed.

When servicing the EGR unit, it is necessary to pay attention to the output gas passages from the engine exhaust manifold and inlet passages in the engine intake manifold. If we overlook this part of the checking procedure, it may happen that we have the EGR unit in order but did not solve the DTC problem as gas passages, to and from the EGR unit, are blocked.

In addition to the carbon deposit preventing the opening of the EGR valve, it can cause a constant partial opening of the valve. In this case we shall have a problem with very uneven engine idling, and the possibility of DTC appearance as-





sociated with a MAP sensor and *Misfire*. So, if we have the trouble code related to the EGR and few additional codes, it would be wise to service the EGR valve first and then deal with other codes if they still exist.

### *CKP sensor DTC problems*

When DTC occurs related to the crankshaft sensor, it is also necessary to make a few checks before deciding to replace the sensor. Before we start with checking the accuracy of CKP sensor, it is necessary to determine whether it is a magnetic inductive sensor, or the so-called *Hall Effect* sensor.

Inductive sensor usually has only two terminals. Using the, previously mentioned, multimeter we can measure the resistance between two terminals on the sensor. The resistance value of particular sensor we can find in the workshop manuals or in data programs. But if we do not have access to the exact resistance values, the meas-

ured values between 200-400 *Ohms* can determine the accuracy of the sensor. The next inspection will determine induced AC voltage output. Switching the multimeter knob to AC (*Alternating Current*), connect the instrument probes to both CKP sensor terminals. When turning the engine with starter, the output voltage must be between 0.2-2V. This value can be also found in the manuals, but this approximate value will be sufficient to evaluate the possible malfunction of the sensor. Namely, in the case of sensor failure, it will not be possible to read the specified value of resistance, nor voltage.

Here is a hypothesis. Suppose that the measurement shows accurate sensor resistance, but the voltage reading fails. Knowing that induction voltage generates at the time when tooth of the pulley arrives on the nose of the sensor, the cause of problem may lie on the toothed pulley or sensor bracket. If there is dirt, which always has metal particles, accumulated between the teeth on the pulley, volt-

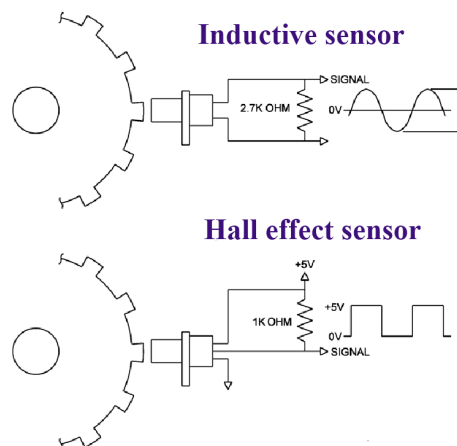
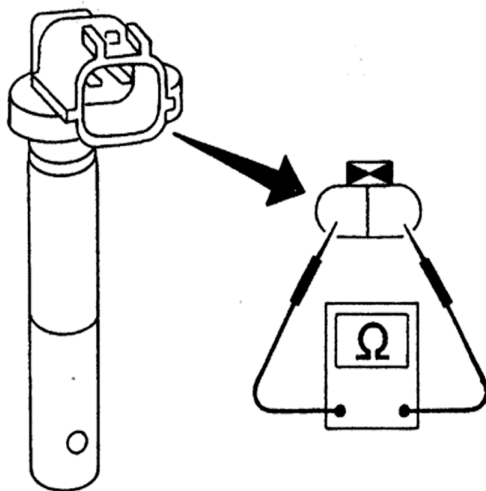



age induction will fail. The same will happen if dirt is present on the sensor. The irregular gap between the sensor and the tooth on the pulley will also be the cause of induction failure. It is not uncommon for a number of reasons that this gap increases or decreases. Therefore, if such irregularity is

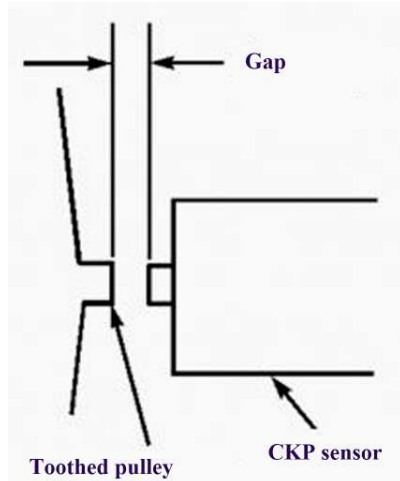

noted, it is advisable to find specified gap distance value and make correction. In the case that we reach a satisfactory measurements and error still exists, the problem could be caused by oxidized contacts on the sensor connector terminals.

When we are talking about CKP sensor connector, it should be mentioned that inductive sensor can have three terminals, which sometimes confuse technicians by leading them to idea that they are dealing with *Hall sensor* which always has three terminals. Inductive sensor has two terminals, while the third is earth connected to the protective mesh covering around the two wires and annuls

foreign voltage interference. If we look carefully wire connections, we shall see that two wires are connected to the sensor and the third one to the protective layer and the third terminal of the connector which is connected to the ground.

*Hall sensor* has the power supply, earth and signal through the connector, thus three active terminals. Unlike inductive CKP sensor, *Hall sensor* output voltage will depend of the moment of the open circuit. Thus, when testing this type of sensor, it is primarily necessary to determine whether there is a power supply (typically 5V) on the sensor connector.

Finally, we should not be surprised if we sometimes encounter two CKP sensors, which manufacturer has provided to read several crankshaft positions. In such cases, the DTC will be marked with the problem of sensor Bank 1 or 2, as it was the case with O2 sensors.

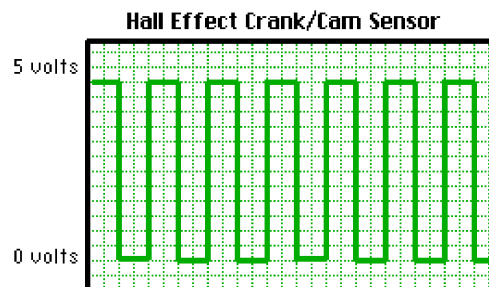
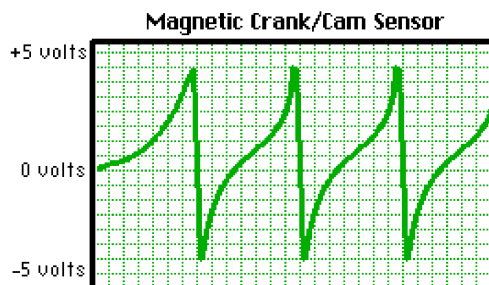

### ***Turbocharger DTC problems***

As in previous cases, the DTC associated with the turbine problem does not refer to its replacement. Suppose that we have a *DTC-P0234* with the definition *Turbo/Super Charger Overboost Condition* or *PO299 Turbo/Super Charger Underboost*. The first definition talks about Turbine or Supercharger overcharging, and the second about the air undercharge.

Worn out shaft bearings will cause the fatal turbine defect. In such case, we shall notice free play when moving shaft left-right by hand. Worn bearings will cause leakage of engine oil, which lubricates the shaft under the pressure, in the exhaust system. Of course, the consequences will be enormous oil consumption, and the blue cloud of smoke from the exhaust. Returning to the mentioned DTCs, we can immediately suspect a malfunction of the turbine *Bypass* valve which diverts exhaust gases (see how Supercharger/Turbines work in the *Automobile electronics & 4-stroke engines*).

The cause of insufficient turbine charging can be carbon deposited on both sides of the blades or turbines *Bypass* valve and its mechanism. Carbon deposit build up on blades, housing and the turbine inlet is caused by worn out engine with excessive oil consumption and large amount of oil vapour on the engine vent. As the engine breather hose is connected to the turbine intake, the carbonized oil

vapour forms deposit inside the turbine. Larger quantities of deposits can slow down the turbine, and sometimes even partially or completely disable its rotation. Another cause may be a partially opened *Bypass* valve, in which case the exhausts gases are not directed to drive a turbine, but a certain amount of gases go directly into the exhaust system by passing the turbine. *Bypass* valve malfunction is usually associated with accumulated soot, which prevents in a timely manner complete opening or closing the flow of exhaust gases to a turbine.

Described problem with a *Bypass* valve will be also the cause of first DTC. If the valve does not, when needed, diverts the exhaust gases by the turbine, the turbine will reach too high speed, and develop excessive air pressure to the engine intake system. If the problem does not lie in accumulated soot, which prevents proper operation of the valve, we should look for potential failure of mechanism which controls the valve. If we find the valve mechanism in order, we should look for the problem in the valve actuator which can be operated by vacuum or solenoid (like the principle the EGR valve).

If we want to clean the carbon deposits from the turbine and disengage *Bypass* valve mechanism, it is advisable to use a liquid to dissolve carbon deposits and do not attempt to disassemble the turbine, as it will cause turbine imbalance. Other parts of the mechanism as-

sociated with the valve could be disassembled if necessary. On following images we see the turbine with vacuum operated *Bypass* valve lever which is adjustable.

When solving the second problem with insufficient turbine



charging, one should bear in mind the possibility of *Intercooler* blockage due to the oil deposited from the engine breather, and carbon deposits on the walls of the cooler.

#### *Wideband O2 sensor with 5 wires*

So far we have mentioned the O2 sensor or lambda probe with 1-4 wires which works as electrochemical generators with the output generated voltage of 0.2-0.9V. This type of sensor on the engine is

certainly of revolutionary importance for the correction of fuel-air mixture. However, the signals received by the ECU simply consist of information YES or NO, or 1 or 0. Thus, the excess voltage generated from 0.45 V will give the information of high concentration of carbon monoxide in the exhaust gases, or too rich mixture. Voltage below 0.45V will indicate the excess amount of oxygen in the exhaust gases, or too lean mixture. By constant mixture adjustments, the ECU will try to maintain the ideal ratio, in which case we shall have output voltage of about 0.45V on the control probe. Striving for the ideal engine operation, maximum efficiency and minimum fuel consumption, manufacturers have developed a new type of O2 sensor that will signal the deviation of fuel injected in each point of engine operation. A new generation of O2 sensor, also known as the *Wideband sensor*, is installed in almost all types of newer production cars. The main difference between this and the previous sensor is, that in this case we have a power supply to the sensor (depending on model) 5V from ECU, instead of generated voltage from the sensor to the ECU. A significant difference was achieved in transmission speed of information and the sensor operating temperature, which is nearly doubled with the sensor heater. Operating O2 sensor temperature ranged around 400 ° C and now is about 800 ° C.

As we said, unlike the standard

*Lambda* probe which generates a higher or lower voltage, depending on the mixture, *Wideband sensor*, also called A/F (Air/Fuel) sensor, will provide a voltage signal which is precisely related to the air-fuel ratio at the time of measurement. The output voltage of the sensor will be converted by an electronic circuit in the sensor to variable electrical signal which can flow in two directions (positive or negative). Electrical signal proportionally increases in the positive direction as the mixture becomes leaner. In the moment of *Stoichiometric* ratio of fuel-air mixture 14.7:1, which is also known as the *Lambda*, the current ceases to flow in either direction. When the mixture becomes too rich, the current changes direction and flows in a negative direction.

ECU supplies the sensor with voltage of 2.6, 3.3 or 5V (depending on the type of vehicle) through the two wires and monitors the sensor output through the two



other wires. The output signal of the sensor is processed in the ECU and can be read by diagnostic device as Air/Fuel ratio or as a voltage signal, what depends of the type of device and programs we use. If we read the probe signal in voltage, value below specified voltage will indicate the rich mixture and the values above specified will indicate the lean mixture. Thus, vice versa from the previous type of sensor. In some cases, the ECU will make a signal conversion, and device will read the value in the same way as it does on old type of O<sub>2</sub> sensor. This modification was done due to the law which provides the reading of all values related to ecology, with the OBD II scanners. The operating principle of this type of sensor is quite more complex than the previous one, but not so important to be completely understandable by mechanics. So, let's just say that only one cell of sensor works in the same way as it does on the older type, and the other one on the principle of *Nernst Effect*, or thermo-electric effect which further processes the amount of oxygen in the exhaust gases and provides more precise information. The most common problems of this type of sensor are associated with defective sensor heating element without which the sensor can not work even when engine reaches the operating temperature. Finally, we should not be surprised if we encounter a *Wideband sensor* with six-wires that has the same function as the one with

five. However, in the case of sensor replacement, we shall certainly use the appropriate one.

### **Evaporative Emission Control System (EVAP)**

The system which ventilates the fuel vapors from the fuel tank may give more headaches, if the DTC turns out associated with it, than solving some other more serious problem.

This system controls the fuel vapors in the fuel tank and prevents them to escape in the atmosphere as harmful gases formed by fuel. ECU or PCM monitors the eventual failure of the system. If a defect is detected, the system turns on the MIL (*Check Engine*). Failure of EVAP system can be caused by a trivial omission i.e., insufficiently tightened tank cap. However, just by tightening the cap, we will not get rid of the DTC and the MIL. Engine computer does not respond immediately to changes in the system, but monitors the system for a while during the driving.

The most common problems associated with EVAP system are connected with the *Purge Valve* malfunctioning. This valve allows the fuel vapor to enter into the en-



gine inlet manifold. Bad condition of system hoses or faulty fuel tank cap will also play a significant role in DTC appearance. One of the common codes encountered is P0440, which warns us about a serious leak from the system. This DTC is usually a result of a lost or loose fuel tank cap, or serious damage of the cap seal. The trouble codes P0443 and P0449 are also common, and directing to the malfunctioning of the *Purge Valve*. Both errors are relatively easily solved. In the first case, we shall check the fuel tank cap and possible damages of the system hoses. In the second case, we shall check the *Purge Valve* and most probably solve the problem.

The trouble code which we certainly do not want to see is labeled P0442. This code indicates a very small leakage from the system, which is almost impossible to find by visual inspection, as the hole is no bigger than a pin head. In such case, we will be forced to use, so-called, smoke machine. Every system has a connector for testing





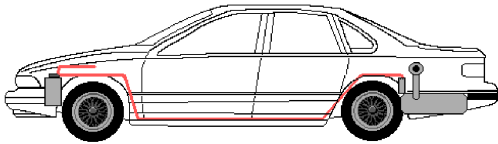

purpose where is possible to attach the stem hose from relatively simple apparatus and fill the system with smoke under a low pressure. Sometimes, such devices have the *UV* colors and leakage can be detected with *UV* detector or simply by following the appearance of smoke on the hoses.

EVAP system completely eliminates the harmful gases from the fuel tank. Accumulated gases stored in *EVAP Vapor Canister* will be released into the engine intake manifold through a *Purge Valve*. The valve will open when engine reaches operating temperature and higher engine RPM when gases will burn in the engine cylinders.

So far, we could conclude that the EVAP system is fully sealed and there is no vent from the reservoir, except during the Purge Valve opening when gases are let to the engine. It is understandable that in such circumstances vacuum would be created in the fuel tank after a certain amount of fuel is consumed, and the fuel pump would no longer be able to supply the engine with fuel. The older types of cars (pre-OBD II system) had a tank cap with a spring valve which opened due to the negative pressure and let the air from the atmosphere into the tank until equalization of pressure was achieved. In EVAP system, the

equalization of pressure is achieved through the *Vapor Canister* and EVAP vent solenoid.

So, let's go now through the EVAP system, from the fuel tank to the engine. The reservoir is designed in a way that the upper part has an additional space for expanded volume of fuel at higher temperatures without fear of fuel overflow in the EVAP system. Fuel tank cap seals completely after closing and has no vent. Vapors from the tank do not go directly into the system, but through the separator *Liquid-Vapor Separator*, which is located at the top of the tank. Vapor enters the separator and the fuel is dripping toward the bottom of the separator and back into the tank, while the vapor is leaving through the hose to the *Vapor Canister*. If we encounter a problem that fuel overflows to the canister, we can suspect the fuel outflow blockage from the separa-

Separator

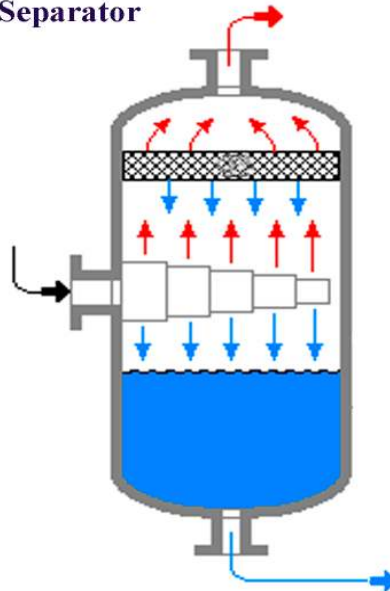

tor in the fuel tank. The attached sketch shows the one of the simple separator, and one should not be surprised if some other type of separator is installed. In any case, it always comes down to the same principle. Separator allows the vapor flow towards the canister and the fuel back into the tank.

Vapor Canister is a plastic or metal container, usually located

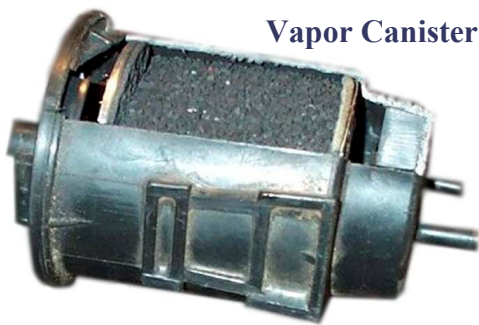

somewhere in the corner of engine compartment. The interior of the container is partially filled with carbon material which acts like a sponge and absorbs the vapor from the fuel tank. During the fuel evaporation while the vehicle is stationary, the vapor is leaving the fuel tank and remains in the canister until we start the engine and reach the operating temperature, when the *Purge Valve* opens and the engine draws the gases in and burn them in the engine cylinders.

ECU will monitor the system

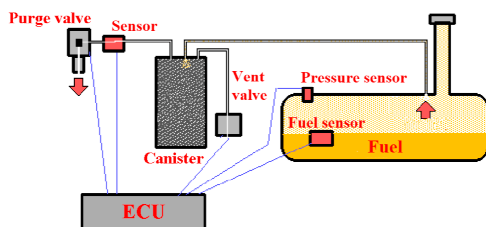

only if the amount of fuel in the tank is between 15-85% of its capacity. The reason is simple. If we have a full tank, evaporation will be insignificant. If we have an empty tank, empty space in the tank will absorb the fuel vaporization.

EVAP *Vent Solenoid* will allow the entry of air into the system in case of large negative pressure in the fuel tank.

### *ECU Flashing and Mapping*

And here we meet one more phrase which is impossible to translate in two words and make it understandable. If we look in the dictionary, we find several meanings for the word *Flash*. Each of these meanings can be used depending of the sentence concept. In our case, we should comprehend what the author wanted to say with this phrase. Thus, the *ECU Flashing* could be explained as quick going over the already installed program in the ECU with the new one, which contains additional or revised information or parameters. Sometimes this term is equated with the term reprogramming. This, by no means, is the same, and therefore we use the term *Flashing*. When reprogramming, the memory is always formatted, all data is removed from it and new program installed. When we do *Flashing*, already installed application is used, and with a new program we are just changing certain settings by quick flashing

through the existing program and updating it with new data and corrected software errors. Because of such procedure, term *Flashing* has been used.

ECU *Flashing* is not always linked, as it is commonly thought, by modifying the program to increase the power. The comparison can be found in Windows programs. In an effort to launch the software on the market as soon as possible there is always possibility of some oversights which are additionally corrected by certain upgrades or updates. So we had the so-called *Windows 98. Second Edition* and *Windows XP Service Pack 2, Pack 3*, etc. which have been used for programs corrections. When we are talking about cars, the situation is similar. A vehicle leaves the factory with an installed program, which after a few tens of thousands kilometers, or other unforeseen driving circumstances shows imperfect. Such imperfections are usually related to the EGR valve, electronically controlled variable camshafts, etc. Namely, when automobile computer is programmed, the ideal parameters are taken in consideration. These parameters change during the various driving regime, and due to the delays of engine actuators after a certain period. To deal with these situations, the car manufacturers are offering modified programs to flash the ECU. This is mainly a simple procedure through the designated interface. Similar to the diagnosis, the pro-

gram takes us through the *Flashing* process, and installs itself a new or corrected program fragments in the ECU.

Apart from described ECU *Flashing* and correcting or repairing installed applications processed by the vehicle manufacturer, *Flashing* can be done with purpose to increase the engine power. Here we have to know that manufacturer has pulled out the optimal maximum power which will, among other things, meet regulatory standards related to ecology. Certainly, when the power was calculated, the engine lifetime was taken in consideration. It is not unknown, that from any engine, especially ones with *Turbo* or *Super Charger*, can be additionally achieved 15-40% of power. Before we proceed with such process, it would be wise to ask ourselves why the manufacturer did not do it. Those who have been mastered the principle of engine operation, will be aware that the increase in engine power will overload its elements: pistons, bearings, clutch ... Therefore, the conclusion is simple. Significantly increased engine power, overloads the engine parts more than it was foreseen, and we can expect a very short engine lifetime. Furthermore, by changing the parameters, we shall most likely go beyond the allowable emissions and therefore passing any technical test will be very doubtful. In other words, if we intend to increase the engine power for more than ten percent, we

must be aware that in addition to modifying the software, we have to do and the hardware too. This means, that we have to consider the cost of replacing a standard piston with modified. It is not rare case that the crankshaft connecting rods have to be replaced too. It should be added the cost of a new (stronger) clutch assembly and modified oil and engine cooling system. The modified exhaust manifold with the entire exhaust system which will allow the proper flow of additional amount of exhaust gasses is also not a negligible item. Other words, it is very expensive game. But this is not the end of the investment. Other parts on the vehicle are designed to resist the power of factory-built engine. After we boost the engine power, we shall have to work on the vehicle suspension and braking system which will not be efficient with new higher engine performances.

Even if increasing the engine power by modified software is not recommended, let's say a few words about this procedure for those who can not resist this challenge from pure enthusiasm, regardless of possible negative consequences. On the market we can find several types of interfaces with programs to increase engine power. In addition to the interfaces and programs for a particular vehicle models, there are those which cover a larger number of car models. Commonly encountered ECU Flashing interfaces:

*CMD Flash, Galletto, KWP 2000 Plus...* If we are going into such experiment, it would be advisable to use programs already prepared for specific vehicle. First what we have to do is to check (usually indicated in the program), if there is a possibility to save original program in our computer before we go on with *Flashing*. This option allows us to return the original program in ECU, if for any reason we are not satisfied with the new version. If we go into the process without being able to save the original program, we will have to contact official service to install back the original program, and pay for it.

Flashing procedure with ready-made software is fairly simple. Connecting the interface is identical to the diagnostic device connection, and the program takes us through the process. A more complex procedure is called *Mapping*, whose name derives from the program map with a number of values which can be changed. Unlike *Flashing* with ready-made software, mapping is a more complex procedure, and we should definitely not play with it, unless we do not know exactly what we are doing. The most common result of improperly performed mapping is the rough engine running and the whole bunch of problems in the best case. Inability to start the engine after incompetently performed mapping is more than common. But if we have saved the original program in our computer,

we shall be always able to install it back in the ECU.

If we use the interface *KWP 2000 Plus*, its package includes the program with listed types of automobiles on which the *Flashing* can be done. Besides the program where ECUs and vehicles are listed, we shall get an additional list of vehicles on CD. After each type of vehicle on the list and the specified ECU, we shall see remark from which is visible whether is possible to previously store the original program or not. If there is no possibility to save the original program, it is advisable to quit *Flashing*. If our car has been found on the list with the possibil-

ity of saving the program, plug the interface in the DLC, start the program and select the type of car from the list. By starting the program, process of reading the EEPROM chip in the ECU begins (EEPROM explained in *Automobile electronics & 4-stroke engines*). If we doubt the identity of the specified ECU in the program and the one in our car, in the next window we shall choose the option INFO and wait for the program to read a data from the ECU. After scanning, in the following window we shall see the data and type of ECU in the vehicle. These data should be stored in a separate folder (yellow envelope icon in My

Documents) in the computer, so that we can install it back if necessary. During the various program phases, we shall be warned to switch the ignition on or off. After we have saved original data, we select our vehicle again, open a prepared program from offered option, and check whether the type of ECU in a new window is identical with the one in original program which we have saved. If the numbers are identical, we shall continue with programming. If the numbers differ, we better give up, because the program is obviously intended for some other ECU. After installation is completed, switch the ignition off, click OK, wait for ten seconds

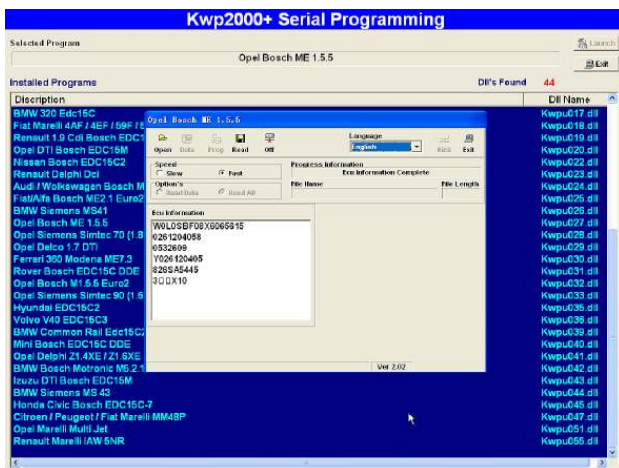



and take the car for test. No matter what at a first glance it looks very simple, before moving to the described procedure, instructions have to be studied thoroughly to prevent any possible mistake. For example, we can find the warning that on some VAG vehicles instrument panel has to be disconnected by removing the fuse, in order to perform the ECU Flashing.

At the end of this chapter, let's take a look to one concrete example of flashing Mitsubishi and Subaru with a program made just for them. As it is the case with the diagnostic tool intended for testing only certain brands of cars, similar situation is with *Flashing* programs and interfaces. Such programs provide far more options than those which cover the entire range of vehicles. In this case, besides the installation of existing modified program, we have the possibility of entering the values of our own choice, or so called mapping.

After starting the program, in the window we can see the upload



of all necessary software tools for *Flashing*. In the upper part of the program we can find the options icons used in the *Flashing* process. With the *Open ROM* option we are opening the program for ECU *Flashing*. With the *Save ROM as* option we can save the changes which we might added in the program. With option *Read from ECU*, we are entering into the ECU and reading the existing program. By clicking on *Write to ECU*, we are writing a new program in ECU. *Test Write to ECU* allows us to test the installation of new program. This procedure is identical to the option *Write to ECU* with the difference that the program is not written into the engine computer, but just the simulation. *Compare to ECU* option compares the ECU program with a program that we want to write and installs the modified data only.

After connecting to the vehicle, icon *Read from ECU* glows. Clicking on the icon, select from a provided list the car model we want to flash. By clicking on *Read*, data starts transferring from ECU to our computer. After completion of transfer, we have a complete data view on

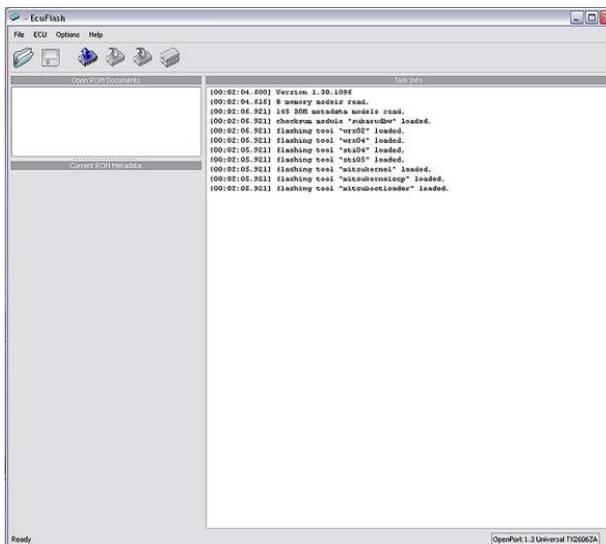

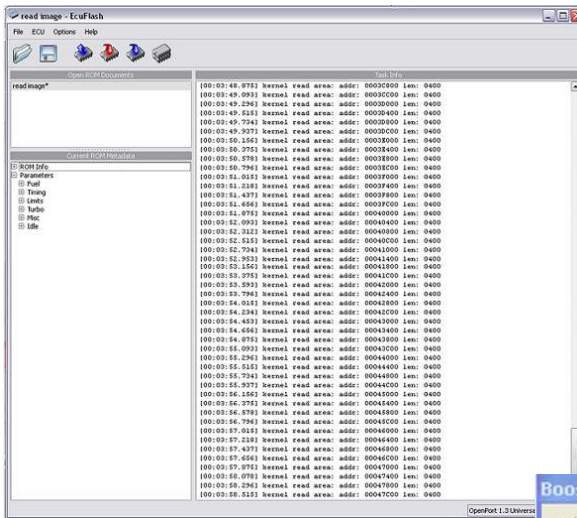
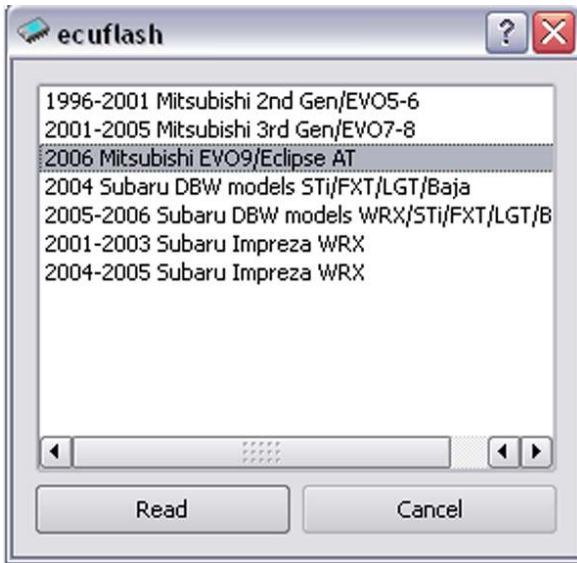

the monitor. These are data and the parameters which are installed in the ECU and have to be saved. Clicking on the *Save ROM as* select a location on the disk, let's say *My Documents*, and save data by click-

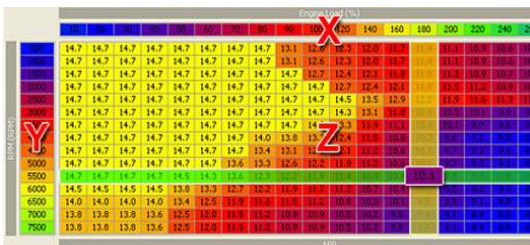

ing on *Save*.

Thus, as previously mentioned, the safest way is installation of modified ready-made programs. Those who wish to play with mapping by typing their own chosen values will have to study quite a lot of material in order to successfully do the mapping. This article will certainly be useful to those who wish to experiment by using ready-made flashing programs. Those more ambitious will have to work on further education. Below on the left we see the fuel map with fuel mixture values which can be adjusted at different engine RPM. In every checkbox values are changed by simply procedure, moving them towards the plus or minus. Similar maps are used for ignition timing correction, opening and closing turbo-charger's bypass, limitation of maximum RPM and setting a number of others

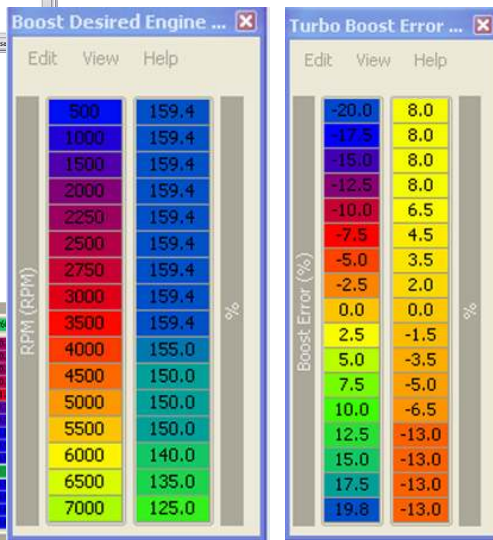



deal with the problems associated with this system, it will be often necessary to use the literature of the car that we work on. In any case, as in the other car components, it is necessary to know the basic operating principle, so that we are

parameters.

### *Immobilizer*

Here we have also an expression which is derived from Latin word *Immobile*. For those who are not quite familiar with its meaning, comparative words would be: motionless, immovable, stationary, static etc. Thus, the term *Immobilizer* can be interpreted as a device which disables something to move, or in our case, disables engine to start.

Early models of immobilizers were quite simple devices, which disabled engine to start by cutting the electrical circuit on ignition coil or ignition module, electric starter, fuel pump etc. Today, these devices are far more sophisticated and connected with the ECU. As there are nowadays a number of different models of immobilizers which are constantly being improved, in this chapter, we shall describe the basic functioning of such devices in today's automobiles. If we want to

able to start from somewhere. At the beginning is important to note that the immobilizer is not associated with the remote door locking control, or with the remote alarm. These facilities incorporated in the ignition key are sometimes confusing, but immobilizer is always a separate device. On the photograph we see the key with an electronic circuit for remote alarm

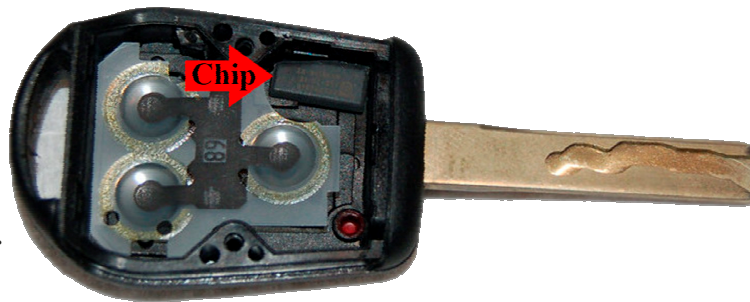

and central locking, and a special section with a microchip linked solely to the immobilizer. Immobilizer microchip is located in the corner of the key housing, while the rest of space is used to accommodate the electronic circuit for the remote alarm and door locking.

To begin with, let's list the components of such a system, starting with the ignition key which is known to us with its mechanical

properties enabling us to unlock the steering wheel lock and turning ignition switch on. On cars with immobilizer, ignition key is called a *Transponder*. This name is a compound of two words: *TRANSmitter* and *ResPONDER*. Of course, these two words are not originally written in this way, the letters are highlighted for easy identification of the compound. *Transmitter* and *Responder* belong to a group of electronic devices which are communicating with radio frequency, or identifying by technology RF-ID (*Radio Frequency Identification*). Since the microchip embedded in the ignition key acts as *Transmitter* and *Responder*, a term *Transponder* was obviously the most suitable name for this electronic circuit.

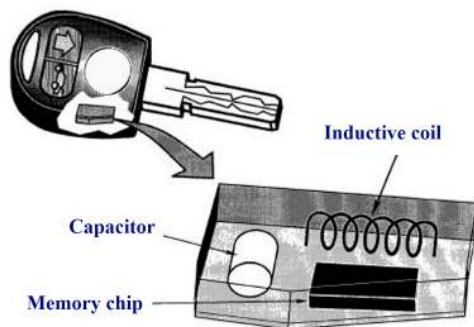

Transponder is powered from the induction coil in the ignition lock (*Antenna Coil*) and does not need batteries. It is not uncommon that problem occurred in immobilizer is often associated with an

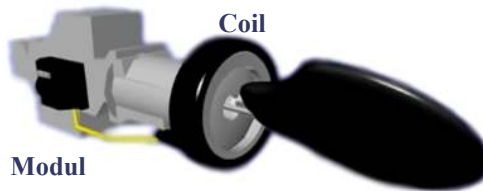

empty battery in the ignition key. If the key has the ability to control central locking and alarm, then it needs battery to power the electronic circuit. In other words, by removing the battery from the ignition key, we will not be able to remotely lock and unlock the car and turn on and off alarm, but we will start the engine without any problems. Transponder supplied with the vehicle is also called *Master key*. The loss of the main key causes extremely delicate situation, which usually results with a considerable loss of time and financial cost. For this reason, it is advisable to make a copy of the *Master key* and store the original key at home. The process of copying, or programming the *Master key* is quite simple. Programming instructions are usually found in the owner's manual which is supplied with the vehicle. If this manual is accidentally lost, the instructions can be found in various auto data, or with little effort on Internet. Of course, it is necessary to obtain the original key through an authorized dealer. Such key comes mechanically



processed for the lock of particular vehicle. The basic program is also installed in the microchip, but it has to be encoded. On the other hand, the market offers so-called uncut or blank keys for certain types of cars. Such keys are much cheaper than original, but are they reliable? Blank key can be mechanically cut by a sample of the *Master key* in the workshops specialized in copying cars keys. After mechanical treatment, the encoding procedure is the same as with the original key already processed

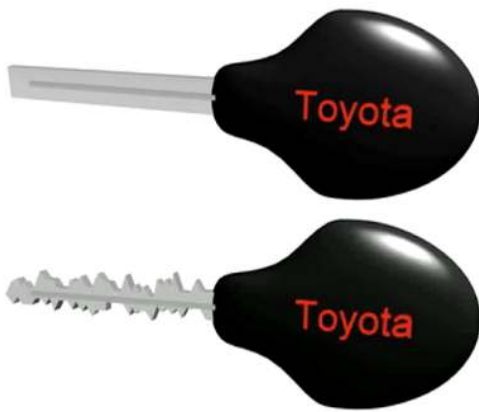

by factory.

The coil on the steering lock powers *Transponder* by incorporating both inductive coils (second coil is placed in the transponder). The primary coil on the ignition steering lock or, more known as a *Coil antenna* or *Transceiver*, exchanges data by radio frequency between the *Transponder* and immobilizer control module. Antenna coil con-

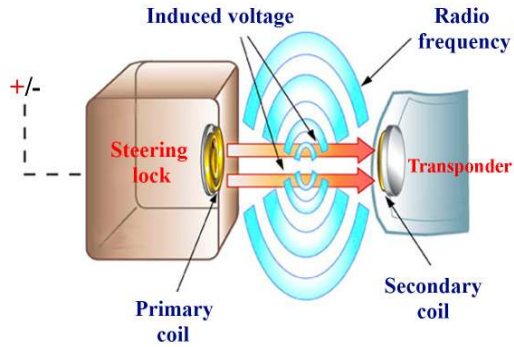
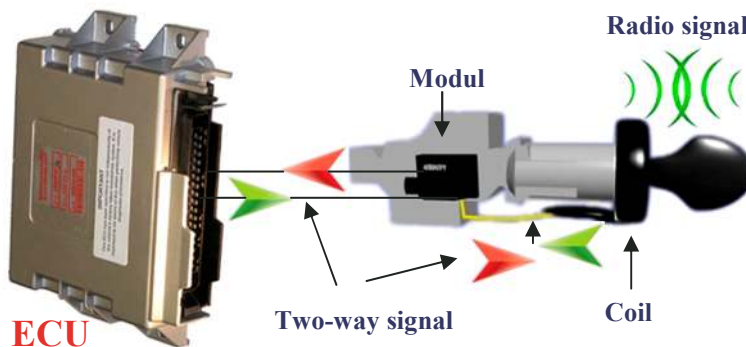

sists of copper coils and an integrated circuit, or microchip, which creates a high frequency AC voltage, and communicates with a transponder. Data exchange between the transponder and *Coil Antenna* occurs when key is turned in the lock. On some models, data exchanges start as soon as key is inserted into the lock.

The indicator light on the instrument panel indicates the immobilizer activation and also warns of possible errors. Activation of the immobilizer is usually accompanied by even flashing, while the eventual defect is manifested by constant light or blink in intervals which are also *DTC* codes. The same indicator light can simultaneously alert about the functions of certain alarm devices activations: the door lock... However, all



devices which are connected to the indicator light are not in connection with the immobilizer. A similar function of the signal lights we meet in the cars where only one light warns us about worn out brakes, insufficient volume of brake oil or disengaged hand-brake.

Unlike the older cars models, today's vehicles *Immobilizers* are connected to the engine computer (*ECU* or *PCM*). By activating *Immobilizer* after removing the key from the steering wheel lock, the *ECU* will (depending of the type of vehicle) immobilize or disable: injectors, spark plugs, starter, fuel valve on the diesel engine etc. The *Immobilizer* module can be separate unit or integrated in the *ECU*.

Well, let's see the process of *Immobilizer* deactivation: By inserting or turning the key in the lock, begins the process of verification or checking. *Immobilizer* module sends a series of numbers over the *Coil Antenna* to the *Transponder*. *Transponder* returns the identification number to the module and calculated response to the received numbers. Electronic *Transponder* chip supplies condenser with power where an induced voltage is stored. Module checks the received identification code and compares it with the registered number in its memory, and also checks the calculated response. Once the module finishes checking, it sends identifying information to the *ECU* where it is compared with stored codes. After comparison, the *ECU* sends

an identification code to the module where it is compared with a code stored in the *Immobilizer* module. After completion of checking, the module returns an identification code to the *ECU*. If verification of identification has passed successfully, the indicator light turns off and the *ECU* deactivates all obstacles to start the engine.

As we see in this very complex system of protection, the *ECU* and immobilizer are closely related. Even so close related, that on large number of today's cars it is not possible to replace just the module or *ECU*, but both. But even this is not always the rule. In some car models it is possible to change the *ECU* and program the immobilizer system in the *ECU* via the module with the original (Master) key. The only component which is not subject to programming is the *Antenna coil*, and can be replaced without fear of unwanted consequences. As already mentioned, if we want to solve the problem related to *Immobilizer*, and if it is not of trivial nature, we will have to study the manufacturer's literature and follow instructions. Successfully resolved or diagnosed problem on the one type of vehicle, does not guarantee success on another. As with a diagnosing the fault on engine electronic system, and here we can read the error by decrypting the number of flashings on the signal lights or by scanning through the *OBD II* connector.

Knowing that many small work-

shops are using second-hand parts, and what will happen in the future too, here is an example of replacing a defective *ECU* with a second-hand one from another car. Knowing how the immobilizer works, we shall certainly insist on buying *ECU* which has a belonging immobilizer module and key or *Transponder*. To make our work easier and reduce the costs, it is not necessary to buy a complete steering lock. We can install other *ECU* into the vehicle, attach the corresponding module to an existing wiring and the existing coil antenna, and a microchip installed in the key which we got with the *ECU*, just switch with the one in original car key. Thus, replaced *ECU* will communicate with the corresponding module and transponder microchip, saving us trouble to change the steering wheel lock and key which usually opens the car door and often activates the car alarm.

Let's see one example of key programming without using an interface and program. Primarily we have to check the possibility of such programming. Information about manually programming can be found in the owner's manual which comes with the vehicle, workshop books for a specific vehicle or other auto data. Described procedure was found in the database and it is foreseen for coding Mazda 6, 1.8, 2002-07. This procedure is used in case of *Immobilizer* system malfunctioning and new keys programming. The system

malfunctioning is manifested by light flashing or constant light, which may be due to a number of causes. In other words, if there has been confusion in communication between the *ECU*, module and *Transponder* for any reason, resulting with inability to deactivate the *Immobilizer*, such a possibility of manually resetting (if provided) will be of great help to quickly resolve the problem. Certainly, we are talking about software problems and not those related to physical defect of one of the system components.

To carry on with such procedure we need to have two originally programmed keys obtained with the vehicle. Each of these operations must be completed within thirty seconds from the end of the previous one. In the lock we insert original key number 1 and switch ignition on. Leave the light on the instrument panel to light up for three seconds, after which it turns off. Within four seconds ignition has to be turned off, and the key number 1 removed from the lock. Insert the original key number 2 in the lock, switch ignition on and repeat the previous procedure. If we are programming new keys, the process has to be repeated with each key, bearing in mind that we have to do it within thirty seconds after the previous procedure is completed. In this case we can program up to eight keys. Thus, before we ask someone for help to program the keys with appropriate software and interface, it is ad-

visible to check the possibility of manually programming.

On cars with no possibility of manually programming, appropriate interface and software has to be used. Here we shall not describe the key programming process with help of interface and program. There has been said quite a lot about the use of interfaces and diagnostic programs. Working with key coding programs is quite similar to the mode of diagnostic programs. Of course, before using the program it is necessary to study

the instructions which come with the program. Following the instructions, the program takes us through the programming process. As the programs are modified day after day, we will find programs on the market for certain types of cars, and those universal covering a number of vehicles. In addition, these programs sometimes offer significantly more options than just encryption keys. On the left photo we see the possibility of errors detection and cleaning, erasing the memory from *ECU*, entering new data, etc. In any case, before we decide to play around with some *Immo* software options, inevitably, should study the instructions and warnings which guide us through the program, because in most cases there is no return after the program phases are wrongly determined.

Service technicians, who are now or will be tomorrow, managers or workshop owners have to know something about dishonest, criminal actions which are not uncommon in workshops all over the world. As it is more or less well known, vehicles are stolen today with the original key, instead by wiring connections as seen on movies. How we can conclude from this text, such theft is absolutely impossi-

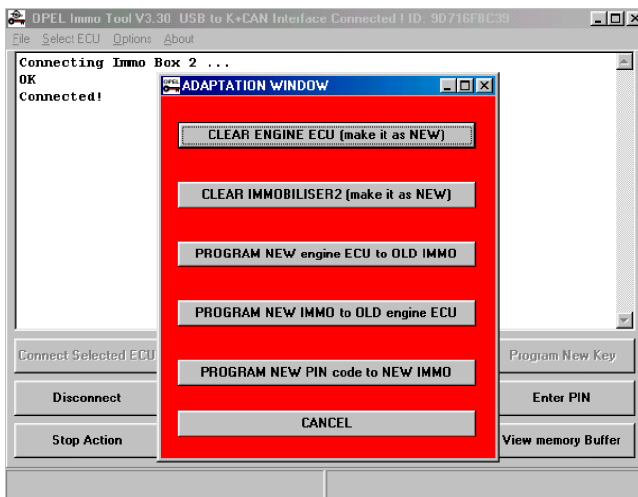
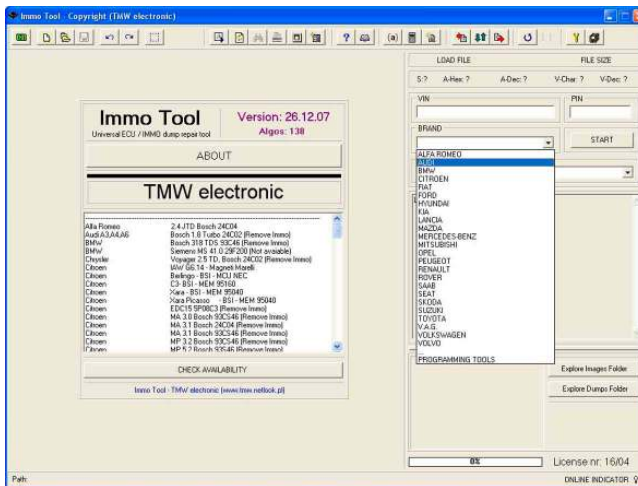

ble for vehicles with integrated *Immobilizer*. However, it becomes quite clear that if costumer leaves the vehicle in the workshop with the master key, there is enough time to make a duplicate key from the original. When we have a cut key by original one, we see how easy is to program it manually or by interface and program. We can only imagine the value of such duplicate key on the "market".

Many will say that in addition to owning a coded key is difficult to jump over the activated alarm on the vehicle. So, let's say a few words about it too. Organized groups of cars thieves are equipped today with very expensive hardware and software equipment. One of the easiest ways to obtain the original key we just described. Another way is to decrypt the code sent by *Transponder* with a help of the laptop equipped with *Microreader-TV*, which can catch radio frequency from *Transponder*. One option to capture radio waves is sitting next to the driver when starting the engine and the other is by sitting next to the car owner who has a car key on the table or in a pocket. By sending signals over a laptop, similar to the one via the coil antenna, transponder sends back a response to a laptop. Program in the laptop identifies the code required by module and *ECU* to deactivate immobilizer. When we have a code saved in the laptop, the whole thing becomes much simpler. Steering lock is unlocked by exist-

ing mechanical key or by force, and the laptop sends a signal to the *Immobilizer* module. In the same way the alarm radio frequency can be caught, and even simpler than *Immobilizer*. For communication with the *Transponder* we should be very close to the chip because its broadcast distance is limited only to twenty centimeters. Radio-frequency remote transmitter which deactivates car alarm has broadcasting distance considerably increased. It is enough to be near the car to catch a signal which will be deciphered in a laptop program. This information is very useful to dealers and car owners, who will, knowing how the codes are obtainable, pay attention to unknown persons who are using laptops in their close distance, particular in the vehicle. For that reason, it is quite understandable why car manufacturers are putting so great effort to add complexity of codes which are emitted by radio frequency. But as we see, for every poison there is antidote.

### *Additional protection from car theft*

Knowing that there is a possibility to copy the key and obtain the protective code from *Immobilizer*, we often come into a situation that we are asked to add more protection against the vehicle theft. Certainly, for this purpose a handful of additional and expensive equipment can be found on the market, which are again more or less based

on the remote control and are no more reliable than those installed by factory. Therefore, in this article we will describe the installation of a simple but effective electro-mechanical theft protection system which is conceptually designed by the author of this book. Shown and described solution certainly does not have to be understood as a revolutionary, because similar solutions can be often encountered in vehicles. However, in addition to existing solutions, it is distinguished by very good performance, effective design, simplicity and cheapness. In addition to learn in this chapter how to additionally protect the car from theft, we shall understand the role of the relay with multiple terminals in a circuit. So let's start from the beginning.

Today, the market offers a whole range of gadgets and devices for additional protection against the vehicle theft. These products are designed for older vehicles which have not factory-built protection, and new models with built-in protection.

It is well known that cars and motorcycles are stolen today regardless of coded keys and alarms. Such theft is never violent, but very sophisticated. Codes are intercepted by electronic devices, followed by starting engine with already prepared key. We have to be aware of fact that Crime is a craft, and theft rarely occurs spontaneously, by the way, or by using a suitable opportunity. Thieves are



learning fast with great effort and are usually well organized into small groups, where everyone performs his job. One of the tasks of such groups is to make contact with employees subject to criminal activities employed in the car services, car washes, hotels, car parks, etc. (statistical data). In these places, car owner leaves the car keys, and often remote device or a code for alarm deactivation. In other words, everything one



needs to make a key print (let's say in clay) and decrypt electronic protection. Next step is quite easy, knowing where the owner leaves his vehicle, one of the group members comes with prepared key and code deactivating device, and without fear or difficulties drives the vehicle away. For this reason, additional protections are offered to lock wheels, gearbox, block the engine, etc. One of the reasons why the owners do not use extra protection from theft is a price of such devices. Therefore, this article provides instructions for making a very effective additional protection, whose price does not exceed fifty dollars and does not take more than couple hours of work.

Hereinafter, with described protection system against the theft is possible to deactivate any engine component which is powered by current when starting the engine. These components include: coils, relays electric starter, electric fuel pump, solenoid fuel valve on diesel engines, etc. By breaking the circuit on one of these elements, engine start is disabled, while all other lights and instrument panel remain in function. Thus, regardless of the possession of original key and alarm deactivator, engine starting is disabled. The same applies to vehicles without alarm when attempted to be violently stolen by breaking the steering lock or bridging ignition wires. By removing the steering lock barrier and bridging ignition wires, the engine will not start. One might

ask, why such idea if so ingenious, is not already on the market, and whether this additional protection can be deactivated, knowing that we are dealing with professional thieves. Nothing is impossible, not even disabling this protection. However, how demanding is such work for thieves?

First, to activate this additional protection we shall install an electric lock which is used on cash registers in shops, cafes... This lock has a cylindrical key which is difficult to copy. In addition, if we leave the vehicle at the above mentioned places, we are leaving protection deactivated, and there is no need to leave its key with the vehicle. So, if the master key has been copied as well as alarm code, there is no chance to copy cylinder key of installed additional protection. Again the question: can this additional lock be destroyed the same as the ignition lock. Well, it will be a problem without serious tools. Cylindrical key does not provide the ability of inserting special tools and violently turning the lock or pulling out the lock cartridge. If we have installed the lock on the hard metal of the instrument panel or the central console, any attempt of demolishing it, will be unsuccessful. The forehead of the lock in which the key is inserted, is very slightly convex and can not be gripped by pliers or any other similar tools. If the back of the lock is reinforced with wide washer before the nut which secures the lock, there is no possibil-

ity of violently pulling or levering it out. The only option to deactivate the system is approaching the lock from the rear side and connecting wires. But, we shall certainly take this option into account when installing the lock. With a little more effort, we shall find very inaccessible place on the inner side of the instrument panel or central console. When installing the lock, we shall partially disassemble the central console or instrument panel to secure the lock from inner side. This means that thief should do the same job to get hold of the rear side of the electric lock. Conclusion: giving up the idea of stealing.

On the shown diagram we see a way of connecting additional protection. In this case we are breaking the circuit on the ignition coil, but in the same way we connect positive wire with any other electrical element. Having broken the original circuit which activates an engine actuator, we have disabled its function. Activation and deactivation of connected element will be controlled by a locked or unlocked position of electric locks. So, let's start the installation process.

The electric lock can be purchased in electrical shops. The same is used in the cash drawers in the shops, restaurants, etc. When purchasing the lock, one should take into account that the key can be taken out in both positions, locked and unlocked. In fact, on some locks, the key can be removed only in locked position.

Price of the lock is about ten dollars. After appropriate lock is found, we shall visit the shop with bolts and nuts and buy a washer with 19 mm bore which is the diameter of the lock. This washer will additionally secure the lock from violent extracting from the bore.

On the instrument panel or central console, we shall find a place to accommodate the electric lock which will be inaccessible from the rear side. At this position we shall drill the 19 mm hole, insert the lock in it, reinforce it with washer and tighten the nut.

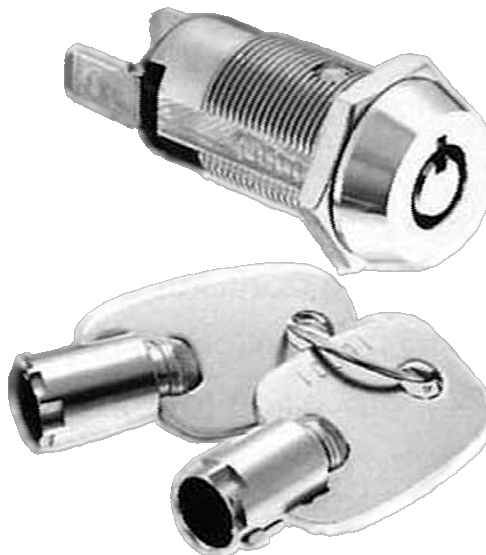

In the auto parts store we shall look for 30 amps five terminals relay. We have to make sure that terminals are labelled with 30, 85, 86, 87 and 87A, as there are identical relays with markings 87 twice (without A). Relay price ranges from 5 to 10 dollars. It is advisable to buy a more expensive relay from reputable manufacturer, be-

cause this cheaper alternative does not meet the specified strength and cause problems, especially if we use it on stronger power consumer. Usually there is a possibility of buying a relay with housing which can be attached to the car body by screw. Such relay will be the most suitable for installation. Those who do not want to install the warning light can use the relay with 4 terminals, 30, 85, 86 and 87. The fifth terminal is used for warning light when the system is activated. If the car already has a built-in alarm indicator light, we shall use four terminal relay and

ignore connecting the lamp shown on the sketch. The relay can be attached to the car body under the instrument panel, central console or inside the engine compartment. If we are going to install the warning light, we have to look for *LED* diode 12 V in the store with electronic goods. Illuminated part of the *LED* is typically 5-6 millimeters in diameter. At a suitable place on the instrument panel will shall drill the appropriate hole and insert the *LED* from inner side. Prior to insertion, couple drops of glue have to be put on the *LED* rim to be fixed in the bore.

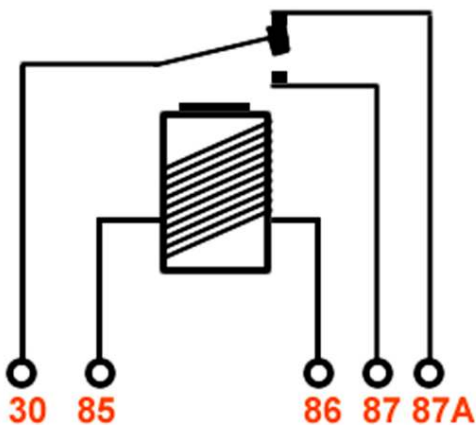

When buying relays and *LED*, we shall ask for fuse with housing with value of 10-20 amps depend-

ing of consumer which is powered by electricity. In any case, we can not go wrong if we use a stronger fuse. The photo shows two types of fuses. The first one is round with glass or ceramic fuse, while the other one has a housing to accept the standard fuse used in today's cars. If we have to choose between these two, preferable would be the second one which, when burned, can be found in vehicle spare bulbs set, or in the nearest gas station.

Of course, we should not forget

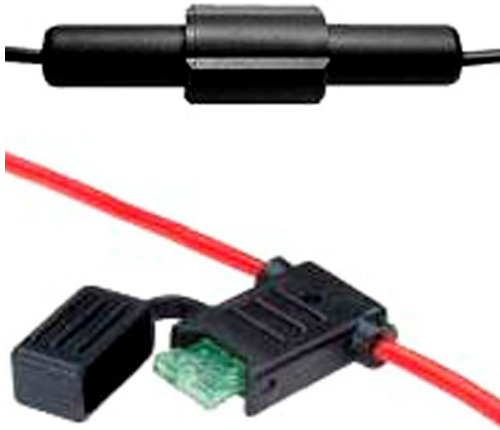

to obtain sufficient quantity of wires, which is sold by meter. Length of needed wire, we can roughly calculate, if we determined elements position of the entire assembly. In the sketch we can see two thicknesses of wires that should be taken into account. For thicker wire, we can use quadrature of 2 mm, and 1 mm for the thinner. To make proper connection, we shall also need wire terminals and insulating tape.

Now, when we have obtained all necessary material, we can start

connecting components. Let's start with the relay. Placing it somewhere under the hood or under the instrument panel, and securing it somewhere with the screw, we can spread wiring towards other components, starting with terminal 30 on the relay. To this terminal we are connecting constant power, from battery or fuse box. For this connection we shall use thicker red wire to which we connect the fuse in serial circuit. When pulling out the power from fuse box, we should make sure that we have chosen source with constant power. This means, that the wire is live when the ignition is switched completely off. Terminal 30 and 85, we shall bridge with thinner red wire. Terminal 87A, we shall connect with positive *LED* terminal using thin red wire. On the drawing we can notice shorter and longer *LED* terminals. Longer wire is always a positive terminal on *LE* diode. So keep in mind when shortening the contacts to remember which wire is positive terminal. Thus, the red thin wire from 87A is connected to *LED* positive terminal. Thin black wire connects diode ground terminal and vehicle ground (any metal part of the body). We are continuing with the thick red wire from terminal 87 to the engine component which we supply with power, in this case, ignition coil positive terminal.

Now we have to connect the electric lock. With thinner black wire we are connecting one terminal to

the ground and the other to the relay terminal 86. If we have properly connected sketched circuit, theft protection system must work. Positioning the key to the locked position, the *LED* will illuminate or blink (depending on the type of diode) and the thicker red wire which is connected to the coil will have no power and ignition is disabled. Positioning the key to unlock position, *LED* will turn off and the coil wire will be energized enabling engine to start. Do not pay much attention to locked or unlocked position of the electric lock, as it depends of lock purpose, in our case this is irrelevant, one position is on and the other is off. How the system works? The relay diagram shows terminal 30, to which we have brought a constant power, connected with terminal 87A when electric lock is turned off. Thus, current flows undis-

turbed from terminal 30 to terminal 87A and to the *LED* positive terminal, whose negative wire is connected to the ground. The circuit is closed and *LED* illuminates. At the same time, inactivated relay does not connect terminals 30 and 87, which supplies with power electric consumer (here we have coil) and engine start is disabled.

Turning the key in the opposite position, we have brought the negative pole from the lock to the relay terminal 86 and closed the circuit between the terminals 85-86 and activated relay solenoid. Electromagnet core is attracted, contacts 30-87A are disconnected and contacts 30-87 are connected. In this position the circuit is interrupted and *LED* turns off. Circuit between terminals 30-87 is closed and the ignition coil is energized.

Concept, design and sketches by R. Marin.

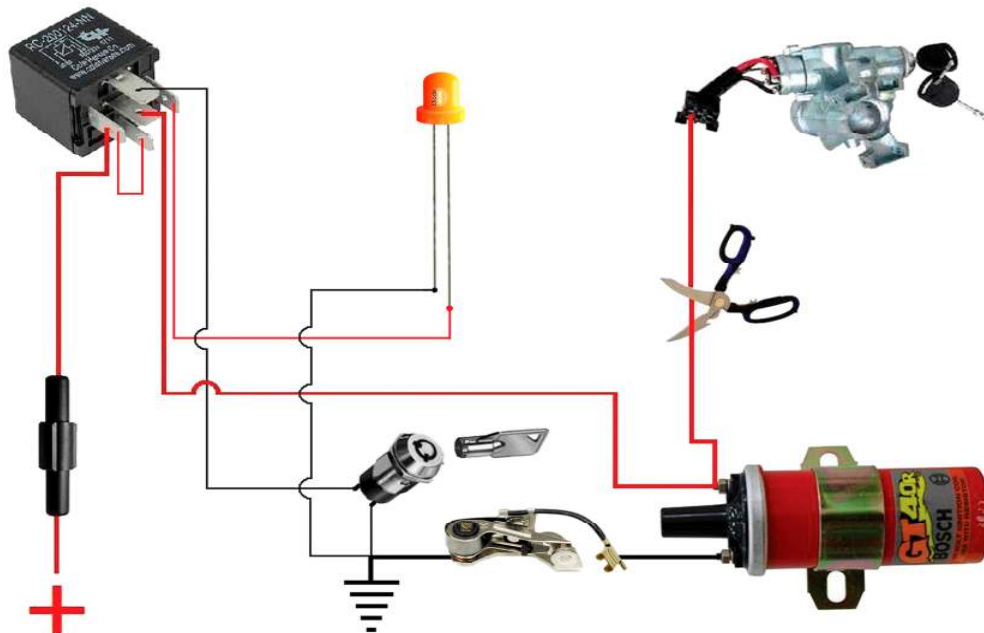



## Radio decoding

Default radio encoding in the vehicles was introduced in order to protect them from theft. The assumption that radios are unusable without a valid code should discourage thieves. Radio sets are mostly blocked immediately after the interruption of power circuit, and on some models with short delay. Namely, interrupted power indicates that radio is removed from the car. If it is removed by the owner or service, there will be no problem about entering code after re-installation. Code usually consists of four digits which are



written in the owner's hand book or in documentation of purchased radio.

It often happens that owner loses the code with the time. The problem appears when replacing the battery or disconnecting it for various reasons. Such a situation requires contacting the car or radio manufacturer to obtain needed code. After the owner's particulars are checked up, the code will be

given to the vehicle owner. When we say verification of ownership, it means checking up information about the owner or a radio, if separately purchased, the vehicle identification number or *VIN* and radio serial number. This procedure is usually simple, but sometimes gets awkward. Therefore, in this section we shall briefly describe radio decoding procedure, which works on most radios.

Decoding code applies only to specific radio. So, to get the code, we have to know the serial number, and sometimes the model of apparatus. Here the whole thing becomes a bit complicated, because we need to draw out the radio from its position in order to read the numbers from the label on its chassis. If the label is accidentally snatched, on most radios the serial number is engraved on the radio chassis. In today's car looks almost impossible to remove the radios from the dashboard as there are no screws, and the whole assembly looks like it was cast from a single piece. Therefore, before we get busy, it is recommended to study the principle of radio extraction, and, if accessible,





In the lower photo we see the radio installed in Ford vehicle which does not have to be removed. In the vehicle handbook we shall find the instructions which say: switch on the radio, hold down the button number 6 and press the button number 2. After that, the radio serial number should appear on the display.

When we write down the numbers from extracted radio, we can return the radio to its place and go on finding the activation code. As it was the case before, for each procedure on an electronic system of the car, we need programs, and often the Internet. If we do not have a program for radio decoding, it can be often found on the Internet. By typing the term *Car Radio Decoding*, we can find dozens of sites which offer online decoding by the serial number (immediately

use the drawings from the manual. Such procedure is quite simple, but it has to be known. We shall also need some simple tools which can be self made.

Before we start extracting the radio in order to read the serial number, it is recommended to go through the possible available literature (sometimes found in the vehicle) to find the possible availability of serial number through the radio display.

returning the code after entering and submitting the serial number). Certainly, such a service has to be



paid about ten dollars by credit card. However, if we type the term *Car Radio Decoder free download*, with a little effort and will, we shall find this option too. Why with the little effort? Because the Internet offers so much for free. But when we come to the downloading procedure, there is only possibility to download demo versions, while the full version has to be paid. Even this is not a bad option if it is a good program which we shall frequently use, and charge our services. However, as I said, those with little more patients will find *Freeware* programs. One such program is shown in the following decoding procedure.

So, as we see in the program photo, the process is very simple. In this case we have chosen the brand of *Becker* radios, and in the newly opened window we type the radio serial number. When clicked on *Calculate* the program prints out the radio activation code. Sometimes, we will have to repeat the procedure because of incorrect

calculations or more codes which can be calculated by program regarding entered serial number, but it just takes few more minutes of work.

In the next example we see the selection of radios selected by the brand of vehicle (in this case *Daewoo*) where the procedure is also simple. But in the following example, *Ford calculator*, we are offered several options. In the first option we are asked for *Ford* code from *PCB* or *Printed Circuit Board*. This seven-digit number is printed on the main board inside radio, or we enter a serial number of the circuit board. Once we enter the numbers, click *Calculate* and radio activation code appears. In the second option we are asked for *Ford's* serial number with the prefix, or the letter before the numbers, and calculating the code with three or four digits. Thus, if we do not know exactly what we are doing, we will play around with all three combinations. Of course, first with the simpler ones if we do not have *Ford's* serial number.

Now when we have an activation code, it has to be entered to the radio. If we do not have any instructions and this seemingly simple operation can give a good deal of trouble. In fact, just writing the code is not a problem, because the numbers are entered by using the numbered buttons on a radio which are also used for direct selection of radio







radio program selection, write a four-digit code which we got from program calculator. After entering the code, press the right side of the button *SEEK* for two seconds until the audio signal is heard. If we have entered the wrong code by any chance, display will show the mark *SAFE* again, and procedure has to be repeated. After two wrong codes entering, we will have to wait at least for an hour before we go again with the procedure.



In the second example, turn on the radio and observe the display label *SAFE*. Press the *MODE* and *SCAN* button until the numerical designation *0001* shows. Enter the code as previously described, and again press the *MODE* and *SCAN* buttons until you hear the audio signal.

programs. However, each radio has a specific procedure for entering codes depending on the model and year of the car production, if the radio is factory-installed. To see how it is done, let's describe two examples of entering the codes in *VW* cars of different ages.

As we see from these examples, even when we have the radio activation code, it is not so simply to enter it without a valid instruction. However, in the lack of instructions used by the car owner, which is usually found somewhere

In the first example, according to the instructions, radio has to be turned on. The display shows the mark *SAFE*. After three seconds, the mark is replaced by a numerical designation *0001*. Typing the buttons from 1-4, for direct



in the gloves compartment, we shall find them, with a little effort, on the Internet.

### *Car parking sensor system*

Today, we are witnessing increasingly complex car enhancements in order to maximize driving safety. One such device is a sensor system and corresponding *ECM* for safe car parking. The sensors are usually mounted on the rear of the vehicle, and it is not uncommon, to find them placed on the front of the vehicle too.

Ultrasonic sensors are commonly embedded in the cars bumpers and emitting high frequency sounds inaudible for the human ear. When sound struck the barrier it bounces back creating an echo which the same sensor receives back. Knowing the speed of sound value, computer, or module of this assembly will calculate the distance between the sensor and the object which vehicle approaches. As vehicle approaches the object behind or in front, the return of

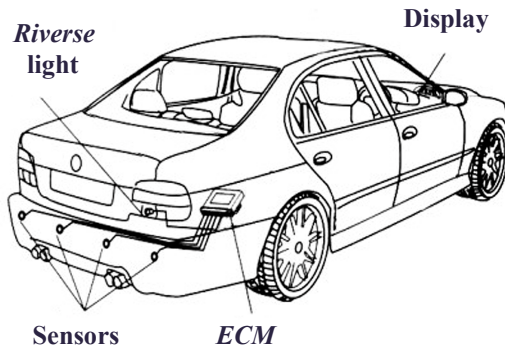

high frequency sound will be faster, it also means a shorter distance. As the width of ultrasound waves is rather limited, the bumper is mounted with up to four sensors to cover all angles of the vehicle. Depending of the embedded system, method of alerting the distance barriers is different. On most vehicles the warning is audible with different intensity of sound which increases as we approaching the obstacle. On some more expensive models displays are build by which we can track distance in meters from the obstacle. In very luxurious car models, beside sensors the cameras are built-in through which we monitor the video projection of the situation behind the vehicle. Someone will say that cameras are luxury considering that there are already sensors which warn us about the obstacle. But, like everything else and these sensors have disadvantages. Ultrasound will ricochet back toward the sensor, if we approach more or less vertical and flat sur-

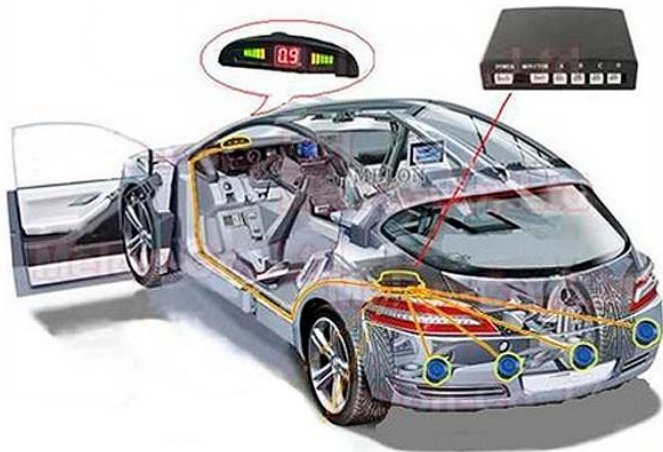





face. But in the case of conical surfaces, protrusions, etc. the sound will be bounced in another direction and the sensor will not detect it. This means that camera system will be highly reliable on the parking, where we are approaching another car or the wall.

However, besides relying on the sensors when parking in various yards and similar places, it is very recommendable to turn the head back and record the area behind the car. Furthermore, even in ideal parking situations, it is not advisable to rely exclusively on sensors. The speed of sound varies with different weather conditions. The parking system computer or *ECM* calculates the distance by the return speed of ultrasonic waves which are defined by speed of sound determined at sea level at a

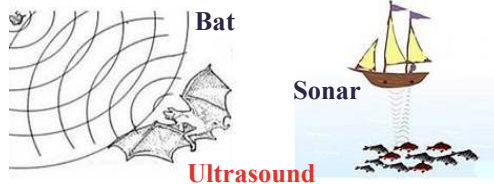

temperature of  $21^{\circ}\text{C}$ . This means that measurements may vary by inches, depending on conditions. For this reason, most of these systems will warn the driver, usually by continuous and amplified audio signal to a maximum closeness to the obstacle, which usually means about twenty inches of space between the vehicle and obstacles.

In addition to ultrasonic sensors, and electromagnetic sensors are used. These sensors produce a magnetic field behind the vehicle controlled by the *ECM*. Driving backward and encountering an obstacle, there will be a distortion of the magnetic field. Based on the data of distorted magnetic field, the *ECM* will calculate the distance from the vehicle barriers. In electromagnetic sensors, measurements are more accurate than ultrasound, and the critical distance can be reduced to ten inches, and even less. Besides being more accurate in measuring, electromagnetic sensors will detect any obstacle behind the vehicle, regardless of ob-



*Electromagnetic sensor taped across the inner side of the bumper.*

ject's form.

When activating the parking system by selecting the gear lever to reverse position, ultrasonic sensors will warn us constantly about the distance from obstacles, no matter whether we are in motion or not. Activated sensors continuously transmit waves and *ECM* calculates the distance from obstacles measuring the speed of waves returning to the sensors. This will not be the case in electromagnetic sensors. If we stop driving in reverse, this type of sensor will stop warning us of an obstacle. The moment when the vehicle has stopped, the magnetic field becomes steady with no changes. As soon as we start moving again, magnetic field becomes disturbed and signalling starts again.

To install ultrasonic sensors, we will have to drill four holes in the bumper and insert sensors in them in a way that the surface of the sensor heads, which are emitting and receiving ultrasonic signals, are visible. The sensors are usually

positioned on each side of the bumper and two on the middle section, in order to cover all angles of the rear side of the vehicle. Electromagnetic sensor, or sensors, may be placed on the inner side of the bumper and do not

have to be visible. Both types of sensors are connected to the *ECM* which processes the received data. Processed data can have output as an audible warning signal of the distance between car and barriers, or sent to the display on the instrument panel transformed to the numbers which define the distance.

As a separate unit, the *ECM* must have the power supply and ground. Wire which activates a system is usually connected to the vehicle tail light where reverse light is positioned too. Selecting gear lever in reverse, we have activated reverse light and thus automatically the system parking *ECM*.

As well as the newer types of cars already come with built-in parking systems, the same can also be retrofitted. With a set which contains the sensors, *ECM* and cables, we usually get a special drill bit to drill the appropriate holes in the bumper, and the wiring diagram. If we purchase a more expensive installation set, in most cases we are supplied with display

which works on the *Bluetooth principle* (wirelessly). Installation is fairly simple. We have to drill the holes in the positions sketched on supplied instructions, install the sensors in them and place the ECM set somewhere inside the car at the rear end. Connect the sensors with module to which we have previously brought the power and ground, and system activation wire to the reverse light. If we are installing electromagnetic sensor system, even drilling is not required because it usually sticks to the inner side of the bumper. Briefly described installation relates to the universal parking sensor kits. If we want to use already provided wiring for parking system installation, we shall look for a set already designed for installation in a particular type of vehicle. We also need to know that the electromagnetic sensor, which is usually supplied as tape, will not work glued to a metal bumper. It will also be a problem with drilling holes for the ultrasonic sensors on the metal bumper. Today, the metal bumpers are rarity, but they can be found on some car models, so it had to be mentioned.

What to say about diagnosing the possible failure on parking system. If it is a factory-built system, errors can be read by diagnostic device. If it is subsequently embedded system, fault diagnosis will depend of the system class or category. Cheaper units just do not provide the possibility of diagnosis. In such cases we will try to find the

fault by checking the power, system activation over the reverse light and checking the sensors with multimeter. With more expensive kits we usually get calibration and fault diagnosing program which usually communicates with our laptop wirelessly. Namely, these devices have the ability to be calibrated after installation. Calibration refers to the value of the sensors readings and those shown on the display and the possibility to determine the critical points when approaching an obstacle.

At the photo below, we see the one of better parking units. In addition to the sensor, this device is supplied with the camera which is installed on the rear of the car and rear view mirror which is also the monitor. The connection between the monitor and the *ECM* establishes on the principle of *Bluetooth*. As we see, the set includes needed drills too.



### *Control Module or ECM repair*

One of the frequent questions asked today by a car technicians, hobbyists and enthusiasts is: whether is possible and how to fix the engine control module *ECU/PCM* or *ECM* of *ABS*, *SRS*, air conditioners, etc.

As already mentioned in this, and in previous book, it is primarily necessary to determine whether the problem is related to a possible malfunction of the control module or some other electronic element. We know that the definition of *DTC* is never specific, but shows the possibility of problems related to sensors, actuators, connectors, wiring and finally the possibility of *ECM* malfunctioning.

Therefore, let's mention one example from the practice which gave a lot of headaches to mechanics. On the *VW Golf 1.4 from 2005* the *DTC* appeared related to a problem with the *MAP* sensor. It was quickly moved to solving the problem by replacing the sensor and believing that problem will be solved. Such action often results with the elimination of failure. But what if not, as it was the case here. The sensor was replaced, but the *MIL* was still on, and the same *DTC* showed up again. After a brief consultation, the team concluded that a problem lies in faulty *ECU* which has to be replaced by new one. Knowing that this is not a small investment, the team decides to ask for help. Advice was similar to those described repeatedly in

this book, and earlier release *Automobile electronics & 4-stroke engines*. If we know how the *MAP* sensor works, we can do some checking before we decide to replace the *ECU*. First, we should check if there is a power supply on sensor from *ECU*. If there is a power supply, what is the output voltage from the sensor at different engine *RPM*. If we have obtained adequate values by measuring, we are suppose to check if these values are coming to the multi pin terminal connector on the *ECU*. Only when convinced that the *ECU* receives a valid signal from the *MAP* sensor, we can conclude that we are dealing with malfunctioning *ECU*. Of course, before we do anything else, we have to check the ground connection of the *ECU*. In described case, the problem was lying in the sensor power supply. By using a voltmeter, conclusion was made, that there is no power supply on sensor connector. It is still not a reason to question the validity of the *ECU*. Voltage was also measured at the *ECU* terminal which supplies the sensor with power. When than a surprise, the team which had quite difficulties with this problem, measured the output voltage of *5V* on *ECU* terminal which supplies the *MAP* sensor with power. At the beginning, a very complex problem suddenly becomes simple. If there is voltage at the module terminal, there must be on a sensor too. A wiring check up showed the damaged wire which was causing

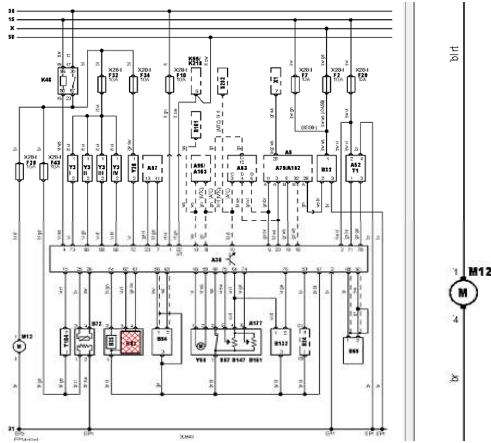

the problem. In addition to damaged wires, the problem could lie in the oxidized terminals in the multi pin connector or in the sensors connector.

Here we have quite clear message. To be able to solve the problem, we have to know how the sensors or actuators work. If we have mastered theoretical principles of the *MAP* sensor, we know that the sensor is supplied with voltage of *5V*, and output voltage from the sensor has a value of *0.5-5V*, depending of air pressure. But how do we find the appropriate terminal on the *ECU*? The one of the ways is to follow the coloured wires from the sensor to multi pin connector on the *ECU*. This method is sometimes impossible. Therefore, we will have to obtain an electronic management diagram for the vehicle we work on. As with other specifications, the scheme will be found in the workshop manual or in one of previously mentioned car data bases. In the upper diagram we see a schematic view of electronic management of our *VW Golf*, which will

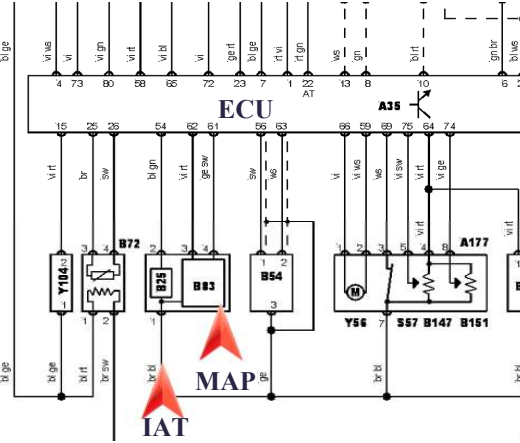

be of significant help in verifications. First, we see that *IAT* sensor is integrated in the *MAP* sensor and connected to the same connector. Blueprint will help us to find out which wire colour belongs to which sensor. On the right enlarged sketch, we see the terminals numbers of each of these two sensors.

If after performing the necessary checks on the wiring and sensors we still come to the conclusion that the *ECU* is faulty, what to do. As we can conclude from the previous texts, the *ECU* is a very complex set of hardware and software. Engaging in its repair requires quite a knowledge and equipment. Still, not everything is so black. If the *ECU* has not been produced so that it can not be opened and its interior completely covered with liquid rubber compound, there is a possibility to observe individual electronic element within it and check its possible faultiness. In this case we will have to obtain a diagram which will help us in locating the sectors within the module. Returning to the previous case of the



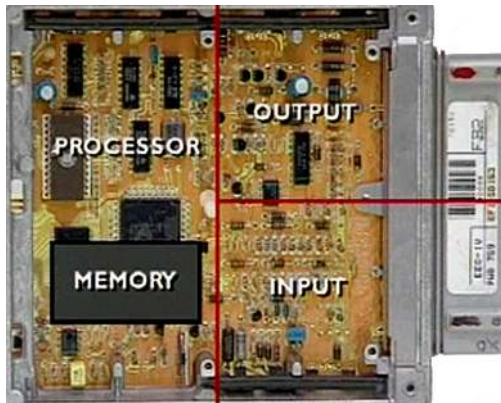

*MAP* sensor, assuming that we had no power on the *ECU* terminal, we shall focus on sector within the module guided by the location of terminal on *ECU* multi pin socket connector.

In the above picture we see the *ECU* roughly divided into sectors. Processor and memory are located in one half, while the other half is divided to the sector of incoming information obtained from the sensors *Input*, and the sector of outgoing information which *ECU* sends to the actuators *Output*. Problems associated with the processor and memory we will not be able to detect, nor repair it. However, the most common causes of problems in the *ECU* are related to the malfunction of individual resistors, capacitors and transistors which we also call relays. If we open the *ECU* by separating the upper and lower protective cover, usually secured with only four screws, we have a very clear view of all electronic elements which are soldered on the

printed circuit. We shall carefully examine entire *ECU* in order to spot any irregularity visible by eye. We can often see charred elements or printed circuit. Knowing that we have a problem with the *MAP* sensor power supply, we shall focus on that sector following the lines which are connected to the sensor power supply terminal on the multi pin connector. Those more experienced will measure the values of resistors, capacitors and transistors in the sector. If we encounter by measuring faulty element, we shall replace it with a new one. If the marks on the defective element are not destroyed, there should not be a problem to obtain a replacement part.

Faulty elements, in most cases, are spotted by visual inspection. On the next photo we see the leaking capacitor whose electrolyte destroyed the printed circuit below it. Replacing such a faulty capacitor usually solves the problem. But what if the printed circuit is destroyed? Those a little more skilled

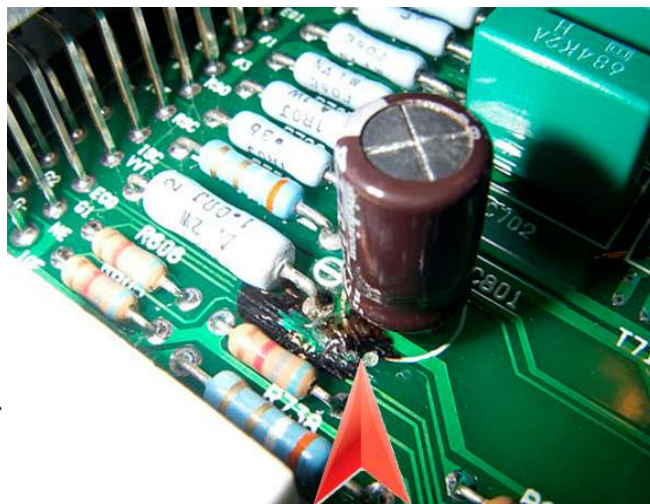

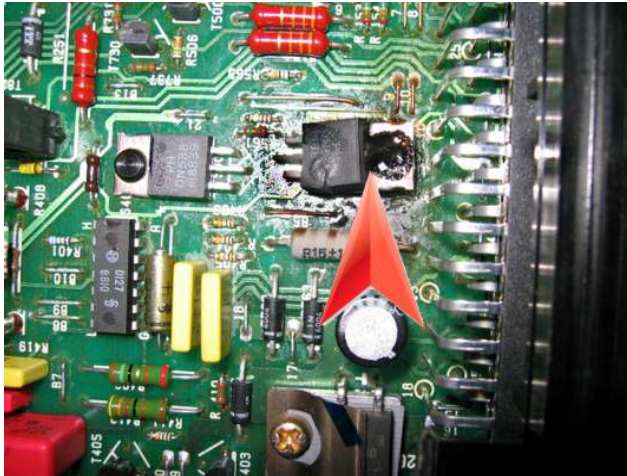

The photo was taken after the transistor replacement, so the picture we see shows a situation with the new transistor labelled with arrow. But if we take look at the plastic lid which covers transistors, we can notice a trace of brown colour on the fourth position which has left burned transistor. I believe that these examples show the possibilities to

with a soldering gun will bridge the damaged printed circuit with a wire and solve the problem. Next photo shows the transistor which is formally destroyed. With a bit of luck, just by replacing transistor, in this case we have solved seemingly quite a serious problem.

In the following situation the *ECU* problem was solved on the vehicle with V8 engine, whose new *ECU* costs quite a lot. The problem was the lack of spark on the one of the engine cylinders. By checking the ignition coil on that cylinder as well as wiring, it was concluded that problem lies in the *ECU*. Fortunately for car owner, the module has been designed to be disassembled if needed, and thus an insight into the situation within it. Each ignition coil has a transistor or a relay inside the module. By visual inspection, it was obvious that one of the eight transistors is burned. By replacing transistor, the problem was solved.

deal with problems of faulty modules. Other failures of control modules can be solved only by specialized companies. If the failure is not related to the mentioned peripheral elements within the module, one should have very serious equipment, software and databases in order to test the module. Among other instruments, it is essential to have the simulator to simulate the signals which *ECU* receives from sensors and instruments to register the signals sent towards the actuators. It is quite obvious that values and programs are not the same for all vehicles, thereby making the job even more difficult. The next photo shows one





of the devices used when the control module has to be repaired.

Being aware of extraordinary complexity of modern technology in today's and tomorrow's cars, it is understandable that it is impossible to expect from the car services completely mastering all professions involved. However, in order to be able to solve the problems related to maintenance and repair of modern cars, at least what we can do is to be familiar with the basic new technology.

In this chapter we saw the possibility of solving some problems related to vehicle control modules. Described examples are seemingly simple, because we found problems by visual inspection and repaired them. In these cases we had lucky circumstances to spot the capacitor and transistor faults visually. But this is not always the case. Control module failures are usually caused by disorder of software, which is usually solved by *Flashing*. Problems are very rarely associated with processor or memory failure, and if so, these mod-

ules will probably have to be replaced. The most frequent problems, as described, are associated with the *ECM* electronic peripheral elements. Knowing how complex is module structure, we will not go further in details studying them and explaining schematically. For the failures that we can repair in the control module, the basic knowledge of electronics is quite sufficient. Thus, as it has been partially described in the book *Automobile electronics & 4-stroke engines*, in simple terms, processor activates transistors located inside the module and transistors are activating actuators. Transistors in a circuit are using resistors and capacitors. Defect in any of these elements will cause a failure of particular sector. Malfunction of electronic elements may not be visible. Therefore, if we suspect the faultiness of particular sector in the module, we will have to test the elements in this part of the printed circuit. Therefore we will concentrate on the purpose of mentioned electronic elements and principle of testing them, as they are usually the cause of failure.

### *Transistor testing*

Here we shall say a few words about the basic principle of transistor functions, as they are commonly present in the automobile modules. Transistor, or even called the relay, is working on a similar principle as already described





electrical relay. It is used for two basic purposes, as a switch or amplifier. In automobile modules it is mainly used as an electronic switch or relay. We will not go into the transistor material structure but only in its working principle. On the first picture we see several types of transistors which vary in their strength. Transistors with a greater flow capacity of electricity are subject to larger scale of warming and are usually attached by a screw to the cooler. We will mention only two types of transistors that are the most common, *NPN* and *PNP* or *Negative-Positive-Negative* and *Positive-Negative-Positive*. The difference between these two types of transistors is in the opposite direction of the circuit.

Transistor is made up of three parts connected to each other, and

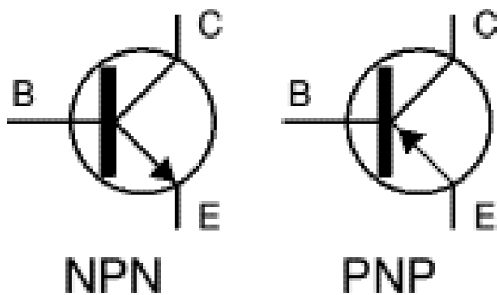

we call them: *E Emitter*, *B Base* and *C Collector*. In some diagrams these marks are also known as: *Source*, *Gate* and *Drain*. On *NPN* transistor, current comes to *E* terminal and leaves from *C* terminal. When transistor is switched off, its central part, or *B Base*, functions as an insulator and the circuit is interrupted. On *NPN* transistor symbol we see diode (arrow) on *Emitter*. It means that current can only flow in one direction, from the *Emitter* to the *Collector*. On *PNP* transistor, the situation is reversed. When voltage comes at *B*, the current flows between the *Emitter* and *Collector*. If we use transistor just as a switch or relay, the voltage at terminal *B* will be defined by a constant value. If we want to leak lower or higher current value through the transistor, it will be regulated by lower or higher voltage at the *B* terminal. In other words, with the higher voltage on *B* terminal, more current flows between terminals *E* and *C*. Thus, the ability of the transistor is a possibility to leak greater amount of current (depends of transistor capacity) between terminals *E* and *C*, being activated by very small voltage through the terminal *B*.

On following drawing we see transistor in the circuit used as a switch. One may wonder why we need a transistor as a switch, when we already have one in the same circuit, which we use to activate transistor via the *B* terminal. Well here's an example: On the

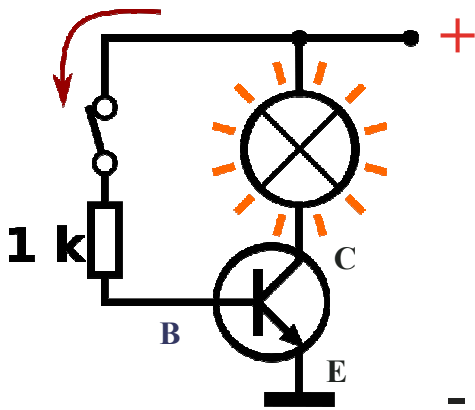

dashboard we have a number of small switches which operate all kinds of electrical consumers. If consumers were activated directly by switches, they should be much more robust to leak enough current. If we connect these switches over transistors, as shown in the sketch, we can use so-called micro-switches through which runs a very small voltage and current, but with enough power to activate transistor through which will flow enough power to run the consumer. Such transistor's characteristics allow us to activate consumers using the voltage produced by solar cells and other sources with low voltage values. In our case, processor will be able to run the actuators using very low voltage across the transistors.

On the lower sketch we used a sliding resistor or potentiometer to regulate the voltage at terminal B of the transistor. By increasing the voltage at terminal B, we are regulating the flow of current through the transistor, thus increasing the intensity of the light bulb, and vice versa. On the first photo of transistor samples we see that all transistors have three terminals. However, transistors located in the metal casing, sometimes have only two terminals. It means that one of the terminals, E or C, is connected to the transistor housing, as it is the case in the lower diagram with the terminal C.

Now that we know how transistor works and what is its purpose we need to know how to test it. For testing electronic elements we used a multimeter before. This is the



one of the essential instruments that we have to have among the others. Transistor can be checked with an ohmmeter, but it is advisable to use a multimeter with option of diode testing. As shown in previous photos, defective transistor is usually noticed by visual inspection. How-

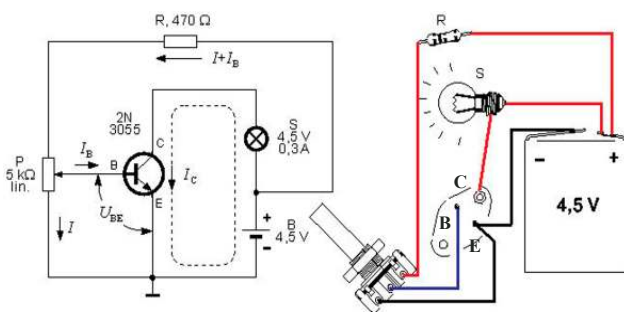



ever, if we doubt its validity, regardless of its physical condition, we shall make the following measurements. For proper measurement of any electronic element, it must be disconnected from the circuit. If we use an ohmmeter, the voltage on probes has to be taken into account, because transistor can be damaged by the higher voltage than it is intended for. By switching the multimeter selector on the diode symbol, we can begin with the measurement. As we are testing a diode, polarity has to be switched while measuring, because, as we know, the diode lets electricity through only in one direction.

Either way that we turn the multimeter probes poles, between terminals E and C must not be a current flow. Between terminals B and E or B and C, current must flow in one direction, depending on which direction diode leaks electricity. Different parameters then above indicate transistor malfunction. On sketches we see, terminals are marked by the letters E, B and C in some kind of order. In practice, transistors do not have a standard for terminals, so when measuring, we do not know which is which terminal. However, since we now know how transistor works, it will not be a problem, with a little effort and help of multimeter, to determine terminals. Let's start with the assumption that our middle terminal is B. Connect positive probe to the middle terminal and negative to the

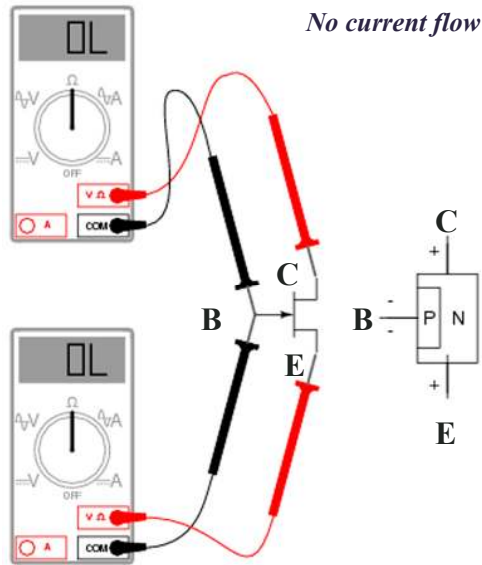

*No current flow*

*Transistor test by changing polarity*

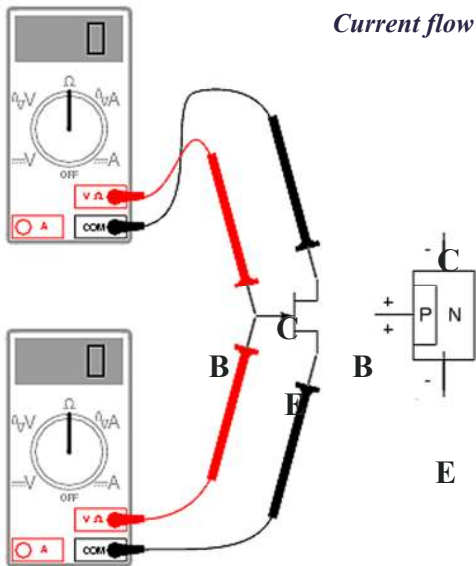

*Current flow*

one end and than to the other. Repeat the same procedure with reversed polarity, negative to B and positive to one and than to other end. If we hit the B terminal and transistor is in order, in one of the tests we shall have a flow of current between terminal B and the one of the end terminals, which is one E and the other C.

## Resistor testing

In previous sketches, we can see that in a transistor circuit, resistors are connected too. In order to define the voltage at transistor terminal B, resistors are used with specific resistance value. If we assume that for any reason, resistor connected in series with the terminal B is faulty, we can simply conclude that transistor also can not function. Faulty resistor will break the circuit to B terminal and transistor will not be activated. The even worse option is the short circuit inside the resistor. If such a resistor regulates the voltage at terminal B, we can surely expect transistor failure due to excessive voltage on the B terminal, which damaged it. On the next sketch we see one, schematically shown, electronic circuit which uses several resistors in circle to regulate the value of the circuit. Defective or abnormal value of each resistor will affect the validity of entire electronic circuit, and can damage other electronic components in the circuit. It is difficult to suggest disconnecting each resistor and measure its value. However, if there is

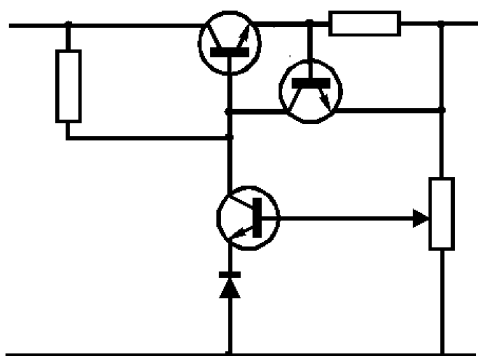

a little doubt in their correctness, and such intervention is cost effective.

Resistor, regardless of the material from which it was made (coil, carbon ...) has the primary function of creating desired (previously defined) resistance in a circuit. Resistor testing is performed again with multimeter selected to the option labeled resistance ( $\Omega$ ). By simple test of resistance we will determine whether resistance exists at all, do we have the open-circuit or short circuit within resistor. Of course, if we obtain these two last results, resistor is faulty. If measuring shows any value of resistance, we can assume that resistor is in order. So, if we have an open circuit, the instrument will not respond when we connect the probes to the resistor terminals. If there is a short circuit inside the resistor, the instrument will have a maximum deflection. If resistor is correct or partially correct, the meter will read some sort of value in Ohms. If we find faultiness by measuring resistor, we shall replace it with a new one with identical markings. If we suspect a measured value, we shall have to use resistor values table. Resistors do not have values written in numbers, but in the colored lines on them. If we want to know the value of resistor which is measured, we shall use the shown table, or any other which can be downloaded

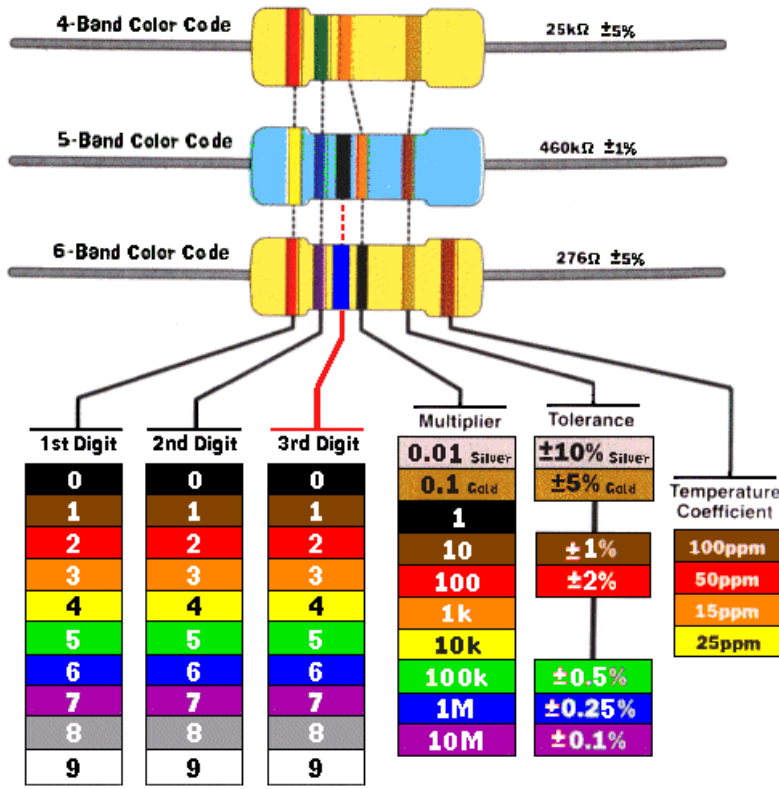

number. For example, if we have a resistor with four colors and read value of two first colors is 25 and after comes the black color, the total value is 25Ω. However, if instead of black, orange color follows, the total value is 25kΩ ... The following marking on the resistor indicates the predicted resistance tolerance in percent. In this case the

from the Internet.

On the above sketch we see an example of reading the resistance value, using the table. If our measured value is within the limits of tolerance comparing with value in the table, resistor is in order. If the value differs significantly, the resistor has to be replaced with new one.

If we take a look at the value table, we see that each color on the resistor has the value in numbers from 0 to 9. The value of the first two colors shows the value in *Ohms* (Ω). Kiloohms and Megaohms (kΩ or MΩ) are determined by the following color, with whose value is multiplied previously read

tolerance is plus/minus 5%. On the resistor marked with six colors, we can see the heat coefficient as the final mark.

At the lower photo we see an example of checking resistor with multimeter.

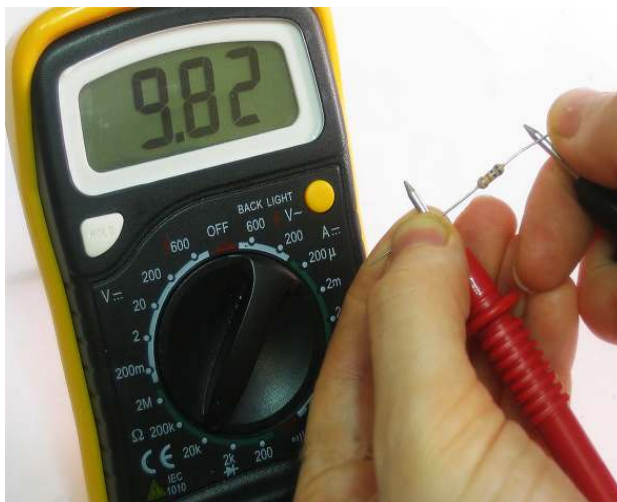



### Capacitor testing

As in previous examples, and here we will concentrate on capacitor basic functions and testing. This basic knowledge of described electronic elements will be sufficient to solve the problem in control modules which can be detected and repaired by ourselves.

Capacitor has the ability to store electricity. Electrolytic capacitor consists of two metal foils (anode and cathode) and the insulator between them. One foil is connected to the negative terminal and the other to positive. Rolled foils are placed in a cylindrical housing filled with electrolyte. If we connect capacitor to the battery, it will be charged

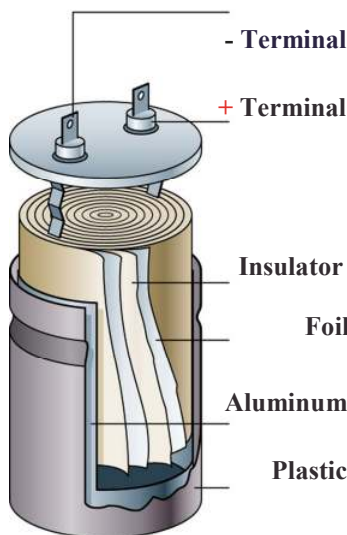

until capacitor voltage equals with the battery voltage. If we connect charged capacitor to the electrical consumer, a rapid discharge will occur. A typical example of capacitors usage is the camera flash. When flash is switched on, capacitor is on charge. The signal light flashes until capacitor is fully charged, or voltage in capacitor equals with battery voltage. By pressing the button for taking photo, flash lamp connects with a capacitor and rapid discharge of high intensity occurs. How intensive is discharge we can see when lightning from the clouds which we also call the capacitor.

Capacitor has defined voltage and capacity which it can handle. Capacity is expressed in farads. In our case, we will meet capacity expressed in *microfarads* ( $\mu\text{F}$ ), although capacity can be expressed in *nanofarads* (nF) and *picofarads* (pF) also. To have a picture why capacity is expressed in microfarad, let's say that one farad occupies the volume of one medium size fire extinguisher. If we divide this volume by one million, we will get a value of one microfarad. Of course, this is just an illustrative example.

Except of, as we said, storing energy, capacitor has the ability to leak alternating current signal, regardless of being fully charged with direct current and stopped absorbing when voltage was equalized. Capacitor will also serve as protection of other elements in an electronic circuit, absorbing all DC

voltage irregularities. Neither here we shall go deeper into the schematic representations of capacitors or the reasons why nor where they are placed in modules circuits. This job is done by the experts in structural laboratories. For us, is sufficient to know how particular electronic elements work, which purpose they serve, how identify them and examine their validity, or failures which are the most common causes of control module malfunctioning. Certainly, those with more will and enthusiasm can go deeper into this matter, but they also have to be aware of its complexity, which entails a lot of learning.

On the first photo we see electrolytic capacitor and the small ones, which in themselves do not have a liquid electrolyte. The first type of capacitor we shall meet more often as it has a larger capacity. Unlike resistors, capacitors are found with labelled values in figures and by letters, like  $6.5V$  and  $200\mu F$ . On the other smaller capacitors, the value is expressed in codes, due to the small printing surface. Displayed label on the condenser with a code  $104W$ , we shall interpret as follows: first two digits indicate the numerical value of 10. The third digit is the multiplier and indicates the number of zeros to be added. Code letter behind the numbers indicates the tolerance value in percentage. As with resistors, and here, if needed, we can use the table to decrypt the value, as well as the interpretation of other marks:

the thermal tolerance, insulators codes, etc. But at our level of possible repairs it will not be necessary, because we will provide replacement by reading the label on the faulty capacitor.

Looking back at the first image, we notice that one terminal of the electrolytic capacitor is longer than the other. Here we have the same situation as with the diode, a longer terminal means positive (+). Sometimes, we shall find polarity indications of the condenser housing. Thus, when replacing condenser, polarity has to be taken in consideration. This second type of smaller capacitors with no liquid electrolyte does not have determined polarity, and terminals have the same length. Such capacitor can be connected either way.

As we mentioned earlier in this chapter, a defective capacitor will be usually spotted by careful visual inspection. Leakage from the capacitor is one of the most common causes of failure. The electrolyte can leak significantly, but can also leave almost invisible traces of electrolyte on the top or bottom of the capacitor. In addition to leakage, we can notice bent top or bottom surface of the capacitor, which are normally flat, and also indicates a defective capacitor. However, besides the visible causes of failure, there is a possibility of damaged metal foil or insulator inside the condenser, which will cause a reduction in capacity or short circuit. Thus, if we doubt the correctness of capacitors and see



no physical signs of malfunction, we shall have to proceed with capacitor testing, using *multimeter* again.

As in previous tests, we will disconnect capacitor from the circuit in order to make measurements. Measuring can be performed by instruments intended for this purpose. As in most cases, we do not have instruments for precise measurement of individual electronic element, and therefore we shall use the *Ohmmeter* on our *multimeter*. Before performing the test, it is recommended to discharge the capacitor. In our case, we can not really experience the shock of capacitor discharge through us, but if it is a stronger capacitor in the circuit of  $220V$ , the consequences may be, say at least, uncomfortable. If we create a short circuit between the capacitor terminals with insulated pliers or a screwdriver, capacitors will be completely discharged. The measurement of capacitor accuracy, we do in the following way: connect the *multimeter* probes to capacitor terminals. Deflection of the pointer must be in the right direction towards the resistance value of zero. After that, the pointer must be deflected in opposite direction of the maximum resistance value. If we get this result, capacitor is in order. If the pointer does not move, it means that we have a broken circuit in the capacitor. If the pointer shows full deflection to the right side where the resistance value is zero and stays there, the

capacitor is a short-circuited and defective in both cases. These measurements are generally reliable when testing capacitor. For accurate capacity measurement, adequate instruments are required.

At the end of this chapter, it is worth to mention a little trick on issues related to software problem in modules, which in most cases helps. Sometimes we find the *DTCs* which just do not make any sense and warn us about failure of something that has not even built in a car, as well as warnings about the lack of communication within the electronic management, etc. Before we seek for help, or go alone in *Flashing*, it is recommended to disconnect the battery for half an hour. After re-connecting the battery, the control module will be reset and thus eliminate possible software errors which occurred



*Testing capacitor with instrument intended for this purpose.*

for any reason. Such problem we often have on home computer. In inability to solve the newly generated problem at the computer, we usually use the *Restart* or *Turn Off* option. When program starts again, everything is as it is suppose to be.

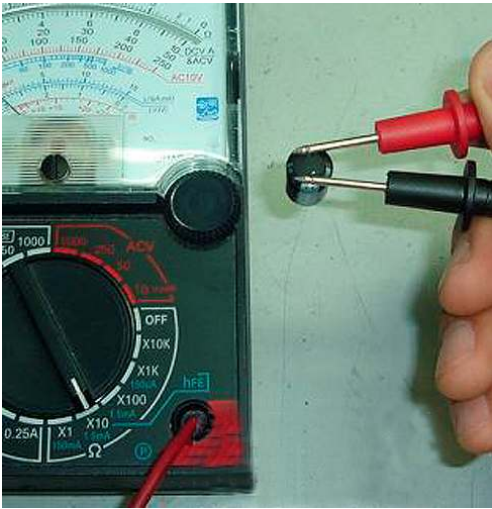

*Testing capacitor with Ohmmeter.*

### *Cruise control*

As we see from the title, *Cruise control* in a literal translation would mean the control of cruising or some sort of travelling around control. Name *Tempomat* which is also used for this device, does not tell us much about the device to which it relates, because its translation would be, some kind of the rhythm control or... So,



here is a descriptive meaning of this device name.

*Cruise control* is a known device which has been incorporated in American cars for decades, and its purpose is to predefine the vehicle speed on long distance, mainly on highways. We all, more or less, know that distance of hundred miles from A to B on American continent, is negligible compared to the European vision of such a distance. In order to enable the driver as comfortable position as possible during extended travelling, car designers have developed a device with possibility to define the vehicle speed and thus avoiding constantly keeping foot on accelerator pedal. As motorways in Europe are expanding, this device is lately popular there too, and we often find them embedded in cars intended for the European market.

Like other appliances, cruise control have evolved over the years to such an extent that they are now almost in a state to operate the vehicle automatically. But let's start with the older models of *Cruise Control* units, which will facilitate our understanding of the principles of modern devices in today's automobiles.



As we said, cruise control allows us to define the travelling speed of the vehicle. For example, if we drive fifty miles per hour and turn on the device, module or *ECM* will remember and keep the speed by the actuator connected to the throttle butterfly or acceleration pedal. If we want to accelerate for overtaking, or for any other reason, we can do this by pressing the accelerator. If we release the pedal after accelerating, the car will continue driving at the speed at which we have previously defined. When brake pedal or clutch is pressed, the device will automatically deactivate. Once we do not want to use *Cruise Control* any more, we will simply turn it off at the command panel, which is located next to the steering wheel.

In the above picture we see a typical *Cruise control* command switch with options: *ON-OFF*, *RES/ACC* (resume or return to the default/speed up) and *SET/COAST* (set/reduce speed). *ON-OFF* switch is used to turn the cruise control on and off. In some vehicles this option does not exist, device is activated by pressing the option *SET* and automatically turns off by

pressing the brake or clutch pedal. By pressing *RES/ACC* or the *SET/ACC* option, we are commanding the module to remember the current speed at which we want to continue driving. With the same command we can increase travelling speed while driving. In other words, if we want to increase the travelling speed, we do not have to press the accelerator and reset the speed, it is sufficient to hold the button, or by typing it, accelerate the vehicle to the desired speed. If we have by any chance turned off the cruise control and turned it on again, preset speed can be recovered by pressing the option *RES* or *Resume*. Holding down the command with the option *Coast*, the car will slow down in the same way as it does when accelerator pedal is released. By typing this command, vehicle speed will be reduced accordingly. When typing commands, speed usually increases or reduces for one to two miles, or we would say, per click. For accurate instructions how to use the *Cruise control* device via the command switch, it is advisable to read the owners manual booklet supplied with the vehicle. The marks on the command are not standardized, so each manufacturer entered its abbreviations and has different ways of management. In this example we have commands: *RES/ACC* and *SET/COAST*, while in some other vehicle we will find commands: *SET/ACCL*, *RESUME* and *COAST*. In any case, it is the same thing but different commands control mode.

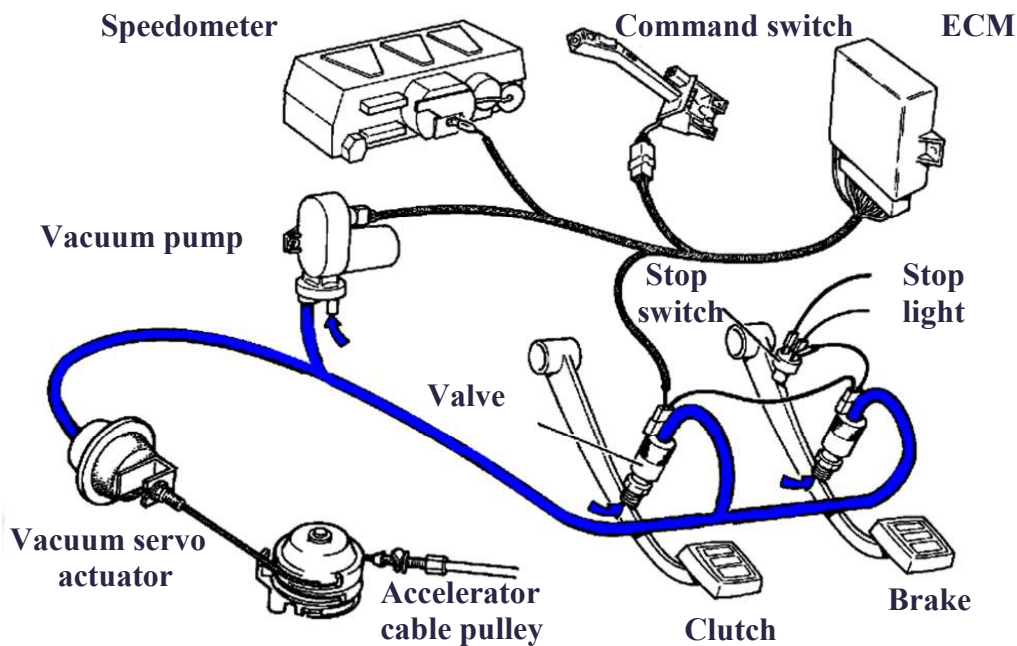

On the above sketch we see all the elements of *Cruise Control* device. In this case the actuator is used to control the throttle pedal and is regulated by vacuum. For this type of cruise control we need a vacuum, which can be obtained from the engine intake manifolds on gasoline engines, vacuum pump on diesel engines or a separate vacuum pump as shown at the sketch. If we use the vacuum from the engine, instead of sketched pump, there will be a valve installed controlled by *ECU* to regulate the vacuum flow. With the command assembly mounted on lever next to the steering wheel, vehicle speed is determined. Having received our command, the module will control the vacuum power by which actuator pulls the throttle cable in position to achieve a given speed. Vacuum servo actuator consists of a chamber divided in two parts by

diaphragm or membrane. The vacuum pulls the diaphragm which is connected to the accelerator cable. Of course, on shown pulley we have two cables which regulate the position of throttle, one from the actuator and the other from the accelerator pedal. Vacuum power defined by module, will pull the cable just as much as it is necessary to obtain a specified car speed. In addition to the command circuit assembly, the module is connected with the inductive vehicle speed sensor. So, whichever commands we send to the module, it will always know the vehicle speed and understand our requirements for adjusting the travelling speed, slowing down or speeding up. When brake or clutch pedal is pressed, the valve will open and allow the entry of atmospheric air into the system and automatically deactivate the actuator. Left with-



out a vacuum or negative pressure, the diaphragm returns to its original position and releases the throttle cable instantly. At the same time, the *ECU* receives a signal through the electrical switch incorporated in the valve and turns off device. If we look at the sketch carefully, we notice that in this case, when the brake or clutch pedal is pressed, vacuum from system is liberated, but module does not receive an electrical signal to deactivate device. It means, that with this device we can press the clutch or brake pedal slightly, and the system will be not deactivated because all switches are connected in series. Only after the brake and clutch pedals are pressed, the electrical circuit is closed through the stop switch and circuit breakers in both valves on pedals. As it can be expected, each manufacturer has developed its own operating principle of *Cruise Control* system with the belief that this is just the most convenient one.

The principle of cruise control is basically always the same or similar. On new car models, the *ECM* will be connected to multiple sources of information about the vehicle movement in order to provide better and safer driving. In these new car models, instead of the vacuum actuator an electric motor will regulate the throttle butterfly opening, while in the car with the electronic accelerator pedal signal transmission to the throttle step motor, opening will be solved through the *ECU*. In

such a vehicle, sliding resistors are used instead of cable, which send a signal to the engine module about the thrust on the accelerator pedal. In the same way, the cruise control module will send information to the *ECU*.

By the development of technology, today's cruise control system

*Vacuum actuator*



*Electric actuator*

devices have reached a remarkable level, and tomorrow...? The cruise control system essentially remains unchanged except that is electronically perfected. On newer car models, sensors are built-in to measure the distance up to 150 meters between the driven vehicle and one moving ahead. The minimum distance between vehicles is programmed in the device module. But for those with higher demands, there is a possibility of adjusting the distance, from maximum also called comfortable to the



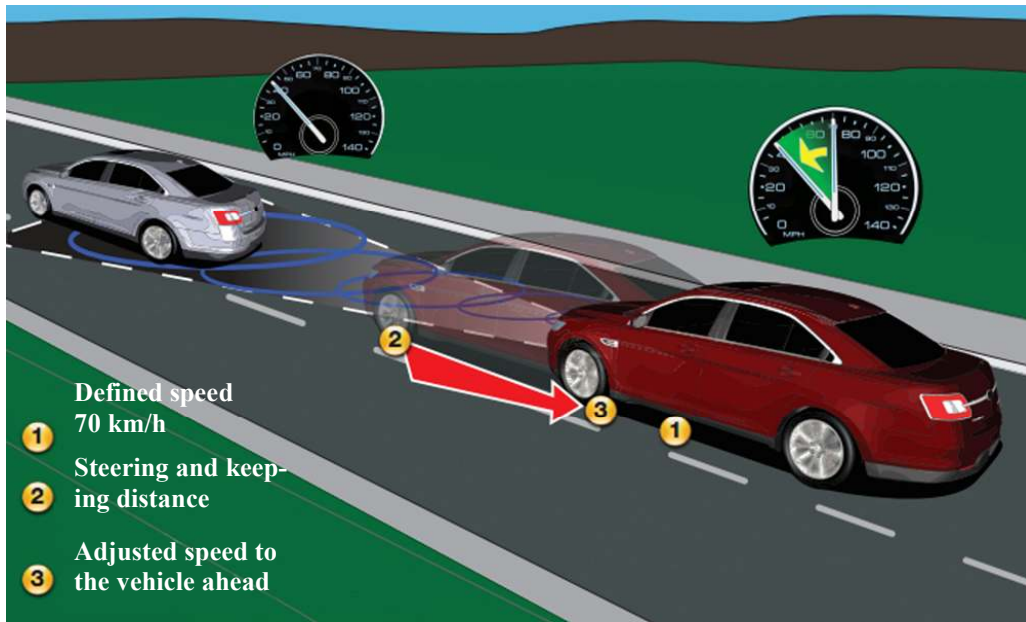

medium or normal, and the shortest one called sport. Selection of distance will depend of the driver, or of his judgement about the response in case of unforeseen situations and behaviour of drivers in vehicles in front of him. Guided by determined distance, *Cruise control* module will reduce the vehicle speed on the base of received signal from the sensor which meas-

ures vehicles distance. Having achieved a given distance, the car will adjust the speed to the vehicle moving ahead. If the vehicle ahead increases its speed, the sensor will provide such information, and module will increase the speed of our vehicle also, taking into account determined distance, and if there is no threat this speed will be set as travelling default speed.





warn the driver with flashing and audible signals, slow down the vehicle, and if necessary stop it. If the module detects a subsequent reaction of the driver, it will suspend all actions provided for such situations.

This sophisticated equipment will be of great benefit to those distracted while driving. In addition to the sensors monitoring the distance between the vehicles in motion, they are able to detect a vehicle ahead which is stationary.

Diagnosing the *Cruise Control* system on newer vehicles is achievable with *OBD II* scanner, as its module is connected to the engine module. Certainly, as in previous cases, the diagnostic device foreseen for particular type of vehicle

Thus, coming to an crossroads where the vehicle has stopped in front of us, the module will receive the sensor signal about the stopped vehicle

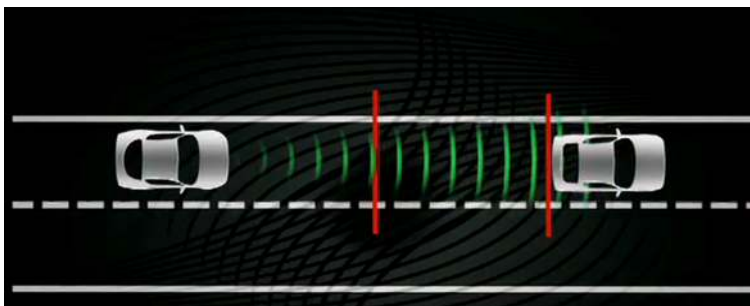

and the possibility of critical distance, as well as the information of no action taken by the driver in terms of the expected slowdown or braking with respect to the situation. In such circumstances, the cruise control module connected to the engine module and *ABS*, will

will be far more extensive in the diagnostic sense, than universal. Problems on old types of cruise controls are usually associated with worn out vacuum hoses, actuators diaphragm, vacuum valves or vacuum pumps. Problems with the proper vacuum sealing and



worn actuators membranes do not always result in complete failure of cruise control system. On the contrary, more often is the case of much lower speed than we determined, due to the significantly weakened vacuum in the system.

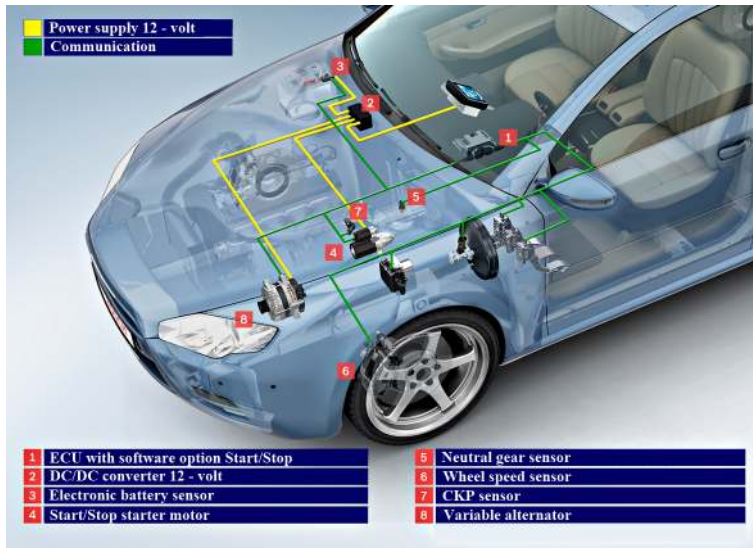

have calculated that this system can save 5-14% in fuel consumption, and thereby simultaneously reducing emissions of harmful exhaust gases. This system is called *Stop/Start* or *Start/Stop*. When brake pedal is pressed and the vehicle completely stops,

### *Start/Stop system*

Today's and tomorrow's automobile technicians must be reconciled with the fact that they will frequently encounter modified existing systems, as well as brand new ones. Mastering the basics through these three books, there will be no difficulties in mastering the principles of operation of each new system, with the help of available literature and software.

In this example we see a new system frequently built in the new vehicles, with the purpose of saving in fuel consumption and further emissions reduction. Designers

engine is automatically turned off, and re-started by releasing the brake pedal or by pressing the accelerator.

Of course, this system is not effective when driving on the open road, but it is certainly efficient in city driving, especially during the rush hours when vehicles are repeatedly stationary for several minutes. This system operates quite simple, but it was modified by time as all other systems. Engine module was added by program to stop and start the engine, and is conducted according to information received from the wheel



speed *ABS* sensor, pedal sensors, gear change lever neutral sensor and *CKP* sensor which tells the *ECU* the engine *RPM*. By pressing the brake pedal, the *ECU* will register a vehicle slow down and wait for information from the *ABS* sensors that vehicle has completely stopped, as well as the fact that the transmission is in neutral position and the engine revs are at a minimum. Depending of program, the *ECU* will wait about five seconds and then stop the engine. Again depending of program, the *ECU* will turn on the engine after the brake pedal is released or by pressing the accelerator. The program which turns the engine off and on will vary on automatic or manual transmissions.

Like all other systems which have disadvantages despite their positive characteristics, this one also has not been spared from negative consequences. The first problem we see in the noise when starting the engine frequently with conventional electric starter, and increased consumption of electricity from the battery. Furthermore, there is a problem with deactivation of all engine-driven aggregates. To solve these problems, a series of modifications are made, where certain aggregates are powered by electric motors. Power steering, previously hydraulic, becomes electric. An additional vacuum pump driven by an electric motor is added, or an additional vacuum tank is mounted for power brakes and others vacuum oper-

ated actuators. All this requires an adequate source of electricity, so it is necessary to provide vehicle with better battery. These modifications and investments are cost effective when it comes to the environmental effect that is achieved with this system. The analyses showed very positive results and effectiveness of this *Idle-Stop* system, and serial standard installation began first in American vehicles followed by MINI Cooper since 2007, Audi's A3, A4 and A5 from 2009, Mazda 3 by the end of 2009 and a number of other manufacturers.

In attempts of solving the mentioned problems associated to aggregates driven by engine in one way or another, big step has been made by modifying the starter motor. The first step was the production of quieter classic starter motor with the new transmission and coupling system. However, as the modification did not turn out with the expected effect, the new idea was born, to start the engine completely silently with electric starter integrated in the alternator. On the following sketch and photograph we see an integrated starter in the alternator which turns the engine silently by the belt.

Solution of integrated starter in the alternator is satisfactory for starting the engine silently, but there is still a

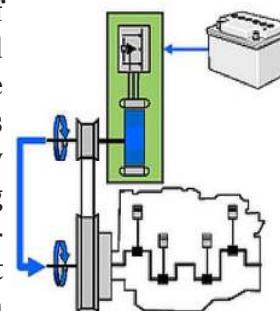





major problem of power consumption. Therefore, this system has a built-sensor which monitors the power consumption from battery. If there is excessive power consumption due to the frequent engine starting and other electrical consumers used during the engine idle, the *ECU* will shut down the *Start/Stop* system until the battery is sufficiently charged.

This problem was solved by the experts of Mazda vehicles manufacturer on diesel engines. Instead of turning the engine with an electric starter, they did it by turning the engine with the engine piston

on power stroke. How does it work? In simple words, using the information from *CKP* sensor, *ECU* exactly knows which piston was on power stroke when engine was turned off. Thus, in the cylinder on the power stroke, the air is compressed and waiting for fuel to be injected. When command to start the engine is received, the *ECU* will inject the fuel into the cylinder. Due to the thrust, piston will turn the crankshaft and the engine continues burning mixture in other cylinders. This technology has passed all tests and the engine is supposed to start in record time of 350 milliseconds, or one time faster than turned on by an electric starter. No doubt that this system is functioning perfectly, if the engine is in such state too. But, what happens if engine is partially worn and compressed air exits through the leakages beside the pistons and valves? Probably, the only solution is one combined system with an electric starter which will help in such cases.

This is a good example of the necessity to understand and improve the knowledge about the DTC's related to this or similar systems.

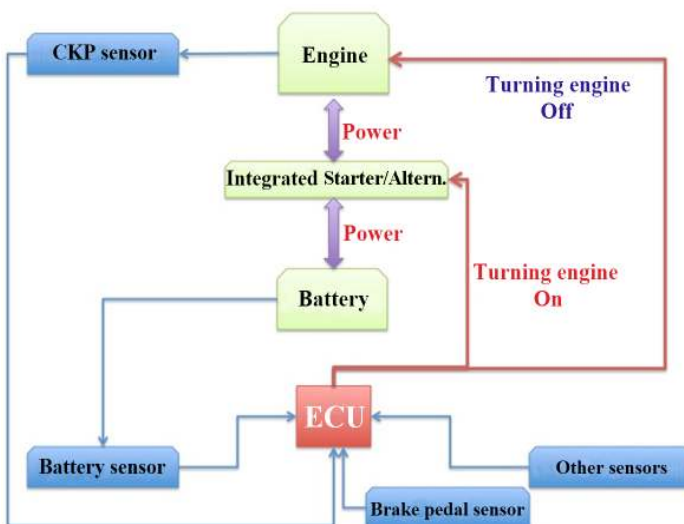



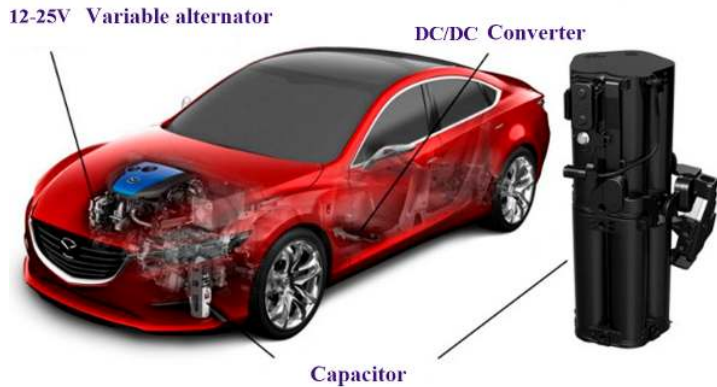

### ***Regenerative braking system***

In chapter *Stop/Start* system we have mentioned the problem of electricity consumption when the engine is turned off and consumers are turned on. Trying to solve this problem, car manufacturers have not only overcome this problem, but generated so much extra electricity with regenerative braking system that fuel consumption is significantly reduced on cars where this system is installed.

Those, who are engaged in vehicle maintenance for longer period of time, will remember the cars with carburetors which did not have idle controlled by *ECU*, but manually adjusted. When idling had to be adjusted, we should take in consideration electrical consumers used during the night or cold and rainy weather. Such consumers are: lights, heater, wipers, fan coolers, etc. Namely, when greater amount of electricity is needed, the alternator creates stronger magnetic field, and thus makes greater resistance on the engine crankshaft pulley which drives the alter-

nator. Due to the great resistance, more power was needed to drive the alternator and the consequence was RPM drop up to ten percent, and sometimes more, which depended of the number of consumers and the engine power.

So, we can conclude that the fuel consumption increased proportionally with the number of electrical consumers involved. Simply said, the fuel used for power to drive the alternator could be used to drive the car. Power used to drive the alternator, could give us some extra mileage, and by simple mathematics, save on fuel.

As in all other cases, the solution here is relatively simple. Change is primarily made on alternator concept which is in this case called a variable. Its primary function remains unchanged. However, by releasing the accelerator pedal, the *ECU* receives information about the engine braking and redirects the alternator function. During the engine deceleration, the alternator, by the orders from *ECU*, increases the magnetic field and generates a voltage of 25V. However, where to store this excess energy? For this purpose, an increased capacity capacitor is used, with extremely rapid charging and discharging. Electricity stored in the capacitor, will be, when needed, converted by the *DC/DC* converter to the value

of 12V, and distributed to recharge the battery and run the electrical consumers. Knowing how often we use the engine in city driving to slow down, we can assume that the capacitor will accumulate more than enough power to run all consumers when engine is turned off by the *Start/Stop* system. Obviously, this is the ideal solution for solving the aforementioned disadvantage of *Stop/Start* system, but where is the savings in fuel? We have concluded that alternator requires a certain power to be driven. To get this power from engine, some amount of fuel has to be burned. Having a sufficient amount of energy stored in the capacitor, *ECU* will deactivate the alternator when accelerating and relieve the engine of extra load usually created by alternator. Only after the battery discharges below the permissible limits due to long rides on the open road, where we rarely use the engine to slow down, the *ECU* will activate the alternator. Vehicle engine relieved of alternator load, could contribute to the savings in fuel consumption up to 10%. This conclusion was made by engineers after series of tests and measurements.

In the upper part of the shown drawing, we see the situation when slowing down with the engine, and when the engine energy is used to activate the alternator and produce additional amount of electric-

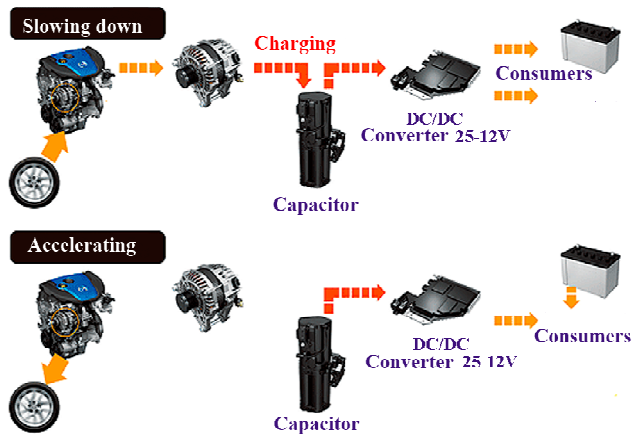

ity. Electricity is stored in the capacitor and through the converter distributed to the battery and electrical consumers.

The lower part of the drawing shows the situation when accelerating or driving, when *ECU* deactivates the main function of the alternator, and all consumers are supplied with electricity from capacitor and battery.

### HHO

From all three books is evident, that, among other things, the theme of reducing the fuel consumption exists from the beginning of automobile industry. Today's cars achieve minimum fuel consumption in relation to performances and power developed. This all is due to the development of electronics which is increasingly present in automobile control management. Enjoyment in driving within the specified consumption limits for a specific vehicle, we can only achieve with correct driving regime. However, this world would not go forward if there are

no people who work tirelessly to improve the existing solutions, even if it is often unsuccessful. First example is the gas conversion system which exists on market for decades. Gas powered vehicles are quite common, and its principle is known to most of us. However, today we can find a number of products which supposedly reduce the fuel consumption. These are the various versions of electronic devices that affect the molecular composition of the fuel, pills that enhance the properties of the fuel, air intake spiral routers, etc. None of these devices have proved conclusively effective. Basically it always comes down to a theoretical explanation based on the laws of physics and chemistry. Of course, in these explanations are taken into account only the parameters which correspond to those who offer such products, while all the negative effects of such devices are not mentioned.

In recent years the media spins very intriguing title: *Driving a car on water*. There are several different versions of this title, but all boil down to the same meaning. Well, let's see what is it all about.

Of course, it would be absolutely wrong to understand the meaning of this title literally. Neither internal combustion engine can run on water, nor can the fuel be mixed with water. Thus, the water through a chemical process is used as an alternative source of additional fuel added to conventional fuels. Once we mention the chemi-

cal process and water, association with electrolysis comes automatically. Exactly, this is what it is all about. Knowing that we need electricity for electrolysis, there was a doubt about this project in very beginning. Namely, there is a well known interpretation that electrolysis can not possible produce more energy than was used in its process. When we draw extra electricity from the generator, we have to provide extra power to drive it, as already explained. But, are the laws of physics finally defined?

So, driving on water comes to the following: By installing the conversion kit, water transforms to *HHO* or Brown's gas. For this electrochemical process electricity is required, and it is only obtainable from the car battery. An alternative source of electrical energy can be solar cells available on the market, and are typically built on top of the car. Brown's gas acts as a stimulant to conventional fuel, and fed separately into the engine intake manifold. Going through the engine intake manifold, *HHO* acts as an oxidant and improves combustion efficiency and reduces emissions of harmful exhaust gases. However, we should not understand all this so easily, because it appears that a number of problems related to car electronics management may occur, as it is not provided for such modifications. The problem is present in the ignition timing, higher engine temperature etc. So, any modification entails a number of side ef-

fects, or, simpler called, problems.

Many will ask, what is the difference between *HHO* and *H<sub>2</sub>O* as in both cases we have two atoms of hydrogen and one atom of oxygen. *H<sub>2</sub>O* is the chemical formula for water molecule in which one oxygen atom is attached to two hydrogen atoms. *HHO* is a mixture of hydrogen and oxygen in the gas form with the ratio of 2:1.

*HHO* system, in theory, is very simple. It consists of an electrically powered electrochemical generator, which in process extracts *HHO* gas from water. The gas is distributed from the generator to the engine intake manifolds and engine idling port. Simple vacuum valve regulates *HHO* entry to one side or the other.

It is not disputed, that this system theoretically increases the combustion efficiency and also lowers fuel consumption. But, could this generator produce a sufficient amount of gas, and in what time. What is the electrical power consumption? If there is enough energy from the alternator, why is recommended installation of additional solar energy or stronger alternators? What is the real effectiveness of this system in terms of fuel savings? How all of this affects the operation of the engine? Are there side effects...?

These are all questions that never had really given convincing answers. But either way, this system is installed in vehicles and is being modified day after day in terms of making more efficient

*HHO* gas generator and proper dosage in relation to the engine RPM.

On the following sketches we see the functioning principle of *HHO* gas generator with other simple elements built into the vehicle. The photograph shows more effective, so-called, dry generator.

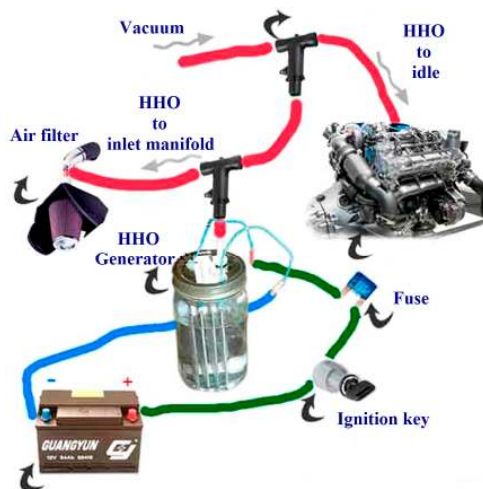
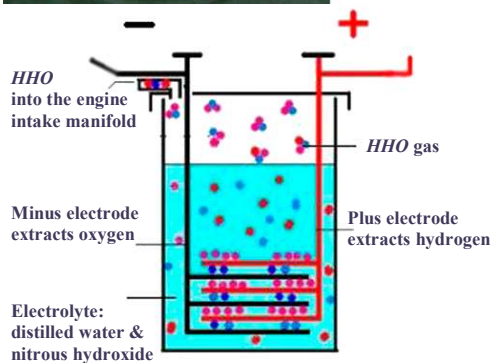







ISBN 978-953-95888-4-5



9 789539 588845 >